

ARISTA



Quick Start Guide

7368X Series Modular Data Center Switches

Arista Networks

www.arista.com

PDOC-00150-01

| Headquarters | Support | Sales |
|--|--|--|
| 5453 Great America Parkway Santa Clara, CA 95054 USA | | |
| +1 408 547-5500 | +1 408 547-5502 +1 866 476-0000 | +1 408 547-5501 +1 866 497-0000 |
| www.arista.com | support@arista.com | sales@arista.com |

© Copyright 2019 Arista Networks, Inc. The information contained herein is subject to change without notice. Arista Networks and the Arista logo are trademarks of Arista Networks, Inc in the United States and other countries. Other product or service names may be trademarks or service marks of others.

Table of Contents

| | |
|--|-----------|
| Chapter 1 Overview | 1 |
| 1.1 Scope | 1 |
| 1.2 Receiving and Inspecting the Equipment | 1 |
| 1.3 Installation Process | 1 |
| 1.4 Safety Information | 2 |
| 1.5 Obtaining Technical Assistance | 2 |
| 1.6 Specifications | 3 |
| Chapter 2 Preparation | 5 |
| 2.1 Site Selection | 5 |
| 2.2 Tools Required for Installation | 6 |
| 2.3 Electrostatic Discharge (ESD) Precautions | 7 |
| Chapter 3 Rack Mounting the Switch | 9 |
| 3.1 Shelf Installation | 9 |
| 3.2 Mounting Ears Installation | 11 |
| 3.3 Switch Insertion into Rack | 11 |
| Chapter 4 Powering the Modular Switch | 13 |
| 4.1 Cabling the AC Power Supply | 14 |
| 4.1.1 Grounding the Switch | 14 |
| 4.1.2 Connecting Power Cables to an AC Power Supply | 15 |
| Chapter 5 Connecting Serial and Management Cables | 17 |
| 5.1 Connecting Supervisor Cables | 17 |
| 5.2 Connecting Linecard Modules and Cables | 18 |
| Chapter 6 Configuring the Switch | 19 |
| Appendix A Status Indicators | 21 |
| A.1 Supervisor Module | 21 |
| A.2 Line Card Module Indicators | 22 |
| A.3 Fan Module Status Indicators | 23 |
| A.4 Power Supply Status Indicators | 24 |
| Appendix B Parts List | 25 |

| | | |
|-------------------|--|-----------|
| B.1 | Parts Used in All Configurations | 25 |
| B.2 | Four-Post Rack Mount Parts..... | 25 |
| Appendix C | Front Panels | 27 |
| Appendix D | Rear Panels | 29 |
| Appendix E | Line Cards | 31 |
| Appendix F | Maintenance and Field Replacement | 33 |
| F.1 | Switch Card Module..... | 33 |
| F.1.1 | Removing Switch Card Module..... | 33 |
| F.1.2 | Inserting Switch Card Module | 34 |
| F.2 | Power Supplies | 34 |
| F.2.1 | Removing a Power Supply..... | 34 |
| F.2.2 | Installing a Power Supply..... | 35 |
| F.3 | Fan Modules | 35 |
| F.3.1 | Removing a Fan Module..... | 35 |
| F.3.2 | Installing a Fan Module..... | 36 |
| F.4 | Supervisor Module..... | 36 |
| F.4.1 | Removing Supervisor Module..... | 36 |
| F.4.2 | Installing Supervisor Module..... | 37 |
| F.5 | Linecards | 37 |
| F.5.1 | Removing Linecard..... | 37 |
| F.5.2 | Installing Linecard..... | 37 |
| F.6 | Optical Transceivers | 38 |
| Appendix G | Regulatory Model Numbers | 39 |
| Appendix H | Taiwan RoHS Information | 41 |

Overview

1.1 Scope

This guide is intended for properly trained service personnel and technicians who need to install the following Arista Networks Data Center Switches:

- DCS-7368X4

Important! Only qualified personnel should install, service, or replace this equipment.

Seul le personnel qualifié doit installer, service, ou remplacer cet équipement.

1.2 Receiving and Inspecting the Equipment

Upon receiving the switch, inspect the shipping boxes and record any external damage. Retain packing materials if you suspect that part of the shipment is damaged; the carrier may need to inspect them.

If the boxes were not damaged in transit, unpack them carefully. Ensure that you do not discard any accessories that may be packaged in the same box as the main unit.

Inspect the packing list and confirm that you received all listed items. Compare the packing list with your purchase order. [Appendix B](#) provides a list of components included with the switch.

1.3 Installation Process

The following tasks are required to install and use the switch:

Step 1 Select and prepare the installation site ([Section 2.1](#)).

Step 2 Assemble the installation tools listed in ([Section 2.2](#)).

Step 3 Attach the mounting brackets and install the switch in an equipment rack ([Chapter 3](#)).

Step 4 Connect the switch to the power source and network devices ([Chapter 4](#) and [Chapter 5](#)).

Step 5 Configure the switch ([Chapter 6](#)).

Important! Class 1 Laser Product: This product has provisions to install Class 1 laser transceivers that provides optical coupling to the communication network. Once a Class 1 laser product is installed, the equipment is a Class 1 Laser Product (Appareil à Laser de Classe 1). The customer is responsible for selecting and installing the Class 1 laser transceiver and for insuring that the Class 1 AEL (Allowable Emission Limit) per EN/IEC 6-825, CSA E60825-1, and Code of Federal Regulations 21 CFR 1040 is not exceeded after the laser transceiver have been installed. Do not install laser products whose class rating is greater than 1. Refer to all safety instructions that accompanied the transceiver prior to installation. Only Class 1 laser devices certified for use in the country of installation by the cognizant agency are to be utilized in this product.

Produit Laser de classe 1: Ce produit a des dispositions pour installer des émetteurs-récepteurs de laser de classe 1 qui offre de couplage au réseau de communication optique. Une fois un produit laser de classe 1 est installé, l'équipement est un produit Laser de classe 1 (Appareil à Laser de Classe 1). Le client est responsable pour sélectionner et installer l'émetteur/récepteur de laser de classe 1 et pour assurer que la classe 1 AEL (limite d'émission admissible) par EN/IEC 60825, CSA E60825-1, et Code des règlements fédéraux 21 CFR 1040 ne soit pas dépassée après avoir installé l'émetteur/récepteur de laser. Ne pas installer des appareils à laser dont la cote de classe est supérieure à 1. Voir toutes les consignes de sécurité qui ont accompagné l'émetteur-récepteur avant l'installation. Seuls appareils laser de classe 1 certifiés pour une utilisation dans le pays d'installation par l'organisme compétent doivent être utilisées dans ce produit.

Important! Ultimate disposal of this product must be handled in accordance with all national laws and regulations.

Aucune pièce réparable par l'utilisateur à l'intérieur. Confiez toute réparation à un technicien qualifié.

The fabric module requires special handling when removing, inserting, or handling the component. [Appendix F](#) provides instructions for handing fabric modules.

1.4 Safety Information

Refer to the Arista Networks document Safety Information and Translated Safety Warnings available at:

<https://www.arista.com/en/support/product-documentation>

1.5 Obtaining Technical Assistance

Any customer, partner, reseller or distributor holding a valid Arista Service Contract can obtain technical support in any of the following ways:

- **Email:** support@arista.com. This is the easiest way to create a new service request. Include a detailed description of the problem and the output of “show tech-support”.
- **Web:** <https://www.arista.com/en/support>
A support case may be created through the support portal on our website. You may also download the most current software and documentation, as well as view FAQs, Knowledge Base articles, Security Advisories, and Field Notices.
- **Phone:** +1 866-476-0000 or +1 408-547-5502.

Important! No user serviceable parts inside. Refer all servicing to qualified service personnel.

Aucune pièce réparable par l'utilisateur à l'intérieur. Confiez toute réparation à un technicien qualifié.

1.6 Specifications

Table 1-1 lists specifications of Arista Data Center modular switches and components covered by this guide.

Table 1-1 7368 Modular Switch and Component Specifications

| DCS-7368X4 | |
|------------------------------------|--------------------------------------|
| Height | 4 RU: 179 mm (7.0 inches) |
| Width | 442 mm (17.4 inches) |
| Depth | |
| Not including handles and ejectors | 559 mm (22.0 inches) |
| Including handles and ejectors | 640 mm (25.2 inches) |
| Weight | |
| Empty | 13.6 kg (30.0 lbs) |
| Fully Loaded | 38.6 kg (85 lbs) |
| Input Power (per circuit) | |
| AC Power | 200 - 240 VAC, 16 A, 50 or 60 Hz |
| Branch Circuit Protection | |
| AC Power | 20 A |
| Input Power Circuits | 2 to 4 circuits |
| Operating Temperature | 0° to 40°C (32° to 104°F) |
| Storage Temperature | -40° to 70°C (-40° to 158°F) |
| Operating Altitude | 0 to 3,000 meters (0 to 10,000 feet) |
| Relative Humidity | 5 to 90% |
| Cooling | 2000 W maximum |

Table 1-2 lists power specifications of modular switch components.

Table 1-2 7368 Modular Switch and Component Power Specifications

| Module Type | Part Number | Power Draw: Typical / Maximum |
|--|---|--|
| Supervisor Modules | DCS-7368-SUP-D DCS-7368-SUP | 30 W / 48 W 30 W / 48 W |
| Linecard Modules | DCS-7368-16C-LC | 63 W ⁽¹⁾ / 144 W ⁽²⁾ |
| Switch Card Module (excluding fans) | DCS-7368X4-SC | 242 W / 406 W |
| Fans | | 23 W / 55 W |
| Power Supplies | PWR-1900-AC | 34 W / 57 W |
| 7368 Series System | Full chassis loaded with 1x DCS-7368-SUP-D supervisor 1x DCS-7368X4-SC switch card 8x DCS-7368-16C-LC line cards 5x Fans 2x PWR-1900-AC power supplies | 961 W ⁽¹⁾ / 1998 W ⁽²⁾ |

(1): Excluding optics.

(2): With 4.5 W optics.

Preparation

2.1 Site Selection

The following criteria should be considered when selecting a site to install the switch:

Floor Space: Install the switch in an area that provides adequate clearance for removing front and rear components. [Figure 2-1](#) displays switch clearance requirements.

Figure 2-1: Switch Component Removal Footprint

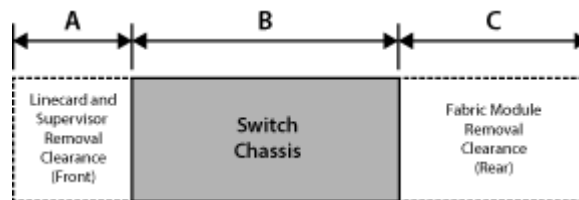

[Table 2-1](#) shows the clearance dimensions for the modular switch.

Table 2-1 Clearance requirements and footprint dimensions

| Switch | Clearance Requirements Dimensions | | |
|------------|-----------------------------------|-----------------------|-----------------------|
| | A | B | C |
| DCS-7368X4 | 25.4 cm (10 inches) | 64.0 cm (25.2 inches) | 55.9 cm (22.0 inches) |

- **Temperature and Ventilation:** For proper ventilation, install the switch where there is ample airflow to the front and back of the switch. The temperature should not go below 0° or exceed 40°C.

Important! To prevent the switch from overheating, do not operate it in an area where the ambient temperature exceeds 40°C (104°F).

Pour empêcher l'interrupteur de surchauffe, ne pas utiliser il dans une zone où la température ambiante est supérieure à 40°C (104°F).

- **Airflow Orientation:** Determine airflow direction of the fan modules and power supply modules. Fan and power supply module handles indicate airflow direction.

Note All power supplies may not be supported by the switch configuration you have.

[Appendix D](#) displays power supply and fan module locations on the rear panel. Verify the airflow direction of all modules (all rear panel modules have the same color handles).

Orient the switch to assure that the air intake modules face the cool aisle. If the airflow direction is not compatible with the installation site, contact your sales representative.

- **Rack Space:** Install the switch in a 19" rack or cabinet. The switch height depends on the switch model, as specified in [Table 1-1 on page 3](#). Verify that the removal clearances ([Figure 2-1 on page 5](#)) provide adequate space for the power and data cables that connect to the switch.

When mounting the switch in a partially filled rack, load the rack from bottom to top, with the heaviest equipment at the bottom. Load the switch at the bottom if it is the only item in the rack.

The accessory kit provides mounting brackets for four-post racks. Two-post mounting racks are not supported.

- **Power Requirements:** Power requirements vary by switch. Refer to [Table 1-1 on page 3](#) for information regarding your specific system.

Multiple circuits provide redundancy protection. The switch uses power cables that have an IEC-320 C19 plug. The accessory kit provides IEC-320 C19 to C20 power cables.

Important! All power input plug-socket combinations must be accessible at all times; they provide the primary method of disconnecting power from the system.

Toutes les combinaisons de fiche-prise d'entrée de puissance doivent être accessibles en tout temps; ils fournissent le principal moyen de coupure d'alimentation du système.

- **Other Requirements:** Select a site where liquids or objects cannot fall onto the equipment and foreign objects are not drawn into the ventilation holes. Verify these guidelines are met:
 - Clearance areas to the front and rear panels allow for unrestricted cabling.
 - All front and rear panel indicators can be easily read.
 - AC power cords can reach from the AC power outlet to the connectors on the front panel.

Important! Disconnecting power to all input sockets is required to completely power off the unit.

Coupure d'alimentation sur toutes les entrées il faut pouvoir complètement l'appareil hors tension.

2.2 Tools Required for Installation

Each switch provides an accessory kit that contains parts for installing the switch into a four-post rack. Two-post rack mount parts are available through your sales representative. Accessory kits do not include screws, nuts, or bolts for attaching the switch to a conventional rack.

In addition to the accessory kit, the following tools are required to install a modular switch:

All Racks

- Mechanical device capable of lifting chassis being installed (chassis weight listed in [Table 1-1 on page 3](#)).

Four-Post Tool-less Rack

No additional equipment required.

Four-Post Conventional Rack

- Screws or rack mounting nuts and bolts.
- Screwdriver.

2.3 Electrostatic Discharge (ESD) Precautions

Observe these guidelines to avoid ESD damage when installing or servicing the switch.

- Assemble or disassemble equipment only in a static-free work area.
- Use a conductive work surfaces (such as an antistatic mat) to dissipate static charge.
- Wear an ESD wrist strap to dissipate static charge accumulation.
- Minimize handling of assemblies and components.
- Keep replacement parts in their original static-free packaging.
- Remove all plastic, foam, vinyl, paper, and other static-generating materials from the work area.
- Use tools that do not create ESD.

Rack Mounting the Switch

The switch must be mounted in a four-post rack. Perform the following tasks to mount the switch.

- Attach the left and right shelf to the rack, adjusting the length of the shelves as needed. You must allocate 4RU rack space starting from the top of the shelf for switch placement ([Section 3.1: Shelf Installation](#)).
- Attach the rack mounting ears to the switch ([Section 3.2: Mounting Ears Installation](#)).
- Use a forklift to insert the switch into the rack ([Section 3.3: Switch Insertion into Rack](#)).
- Secure the switch into place ([Section 3.3: Switch Insertion into Rack](#)).

Note

Components are designed for tool-less installation in square-hole racks.

3.1 Shelf Installation

The four-post mount accessory kit contains these components:

- Left Shelf and Right Shelf
- Rack mounting ears

Follow the steps listed below to attach the shelves to the rack.

Step 1 Extend the sliding end of each shelf so that it can be placed on the rack.

Figure 3-1: Attaching Shelves to the Rack (Right Shelf Shown)

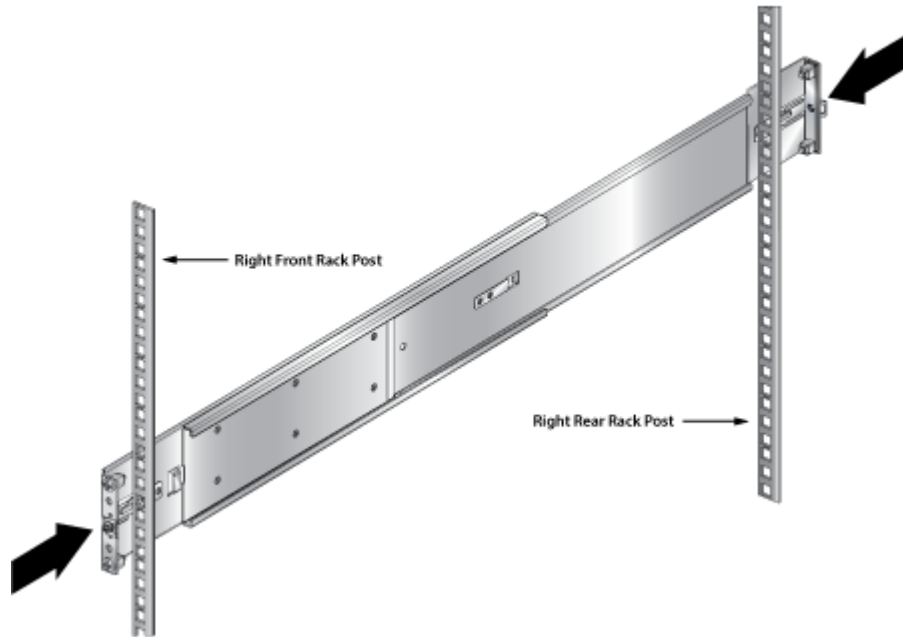

Step 2 Move the sliding end of each shelf so that the shelf fits snug and level on to the rack and secure the shelves using the screws to the rack. (Figure 3-2-left and Figure 3-2-right).

Note You must ensure that the shelves are installed at the same level in the rack.

Figure 3-2: Adjusting Shelves to Fit onto the Rack (Right Shelf Shown)

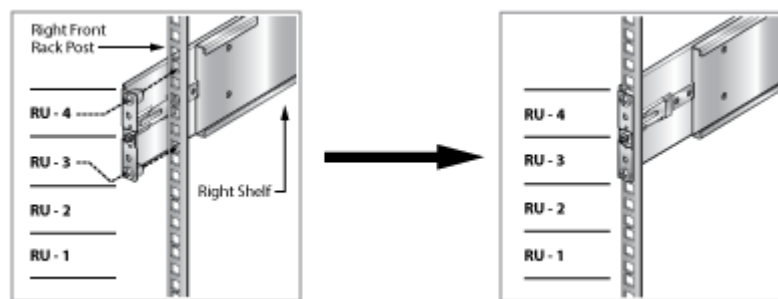

The installed switch shelves are shown in Figure 3-3.

Figure 3-3: Switch Shelves Installed

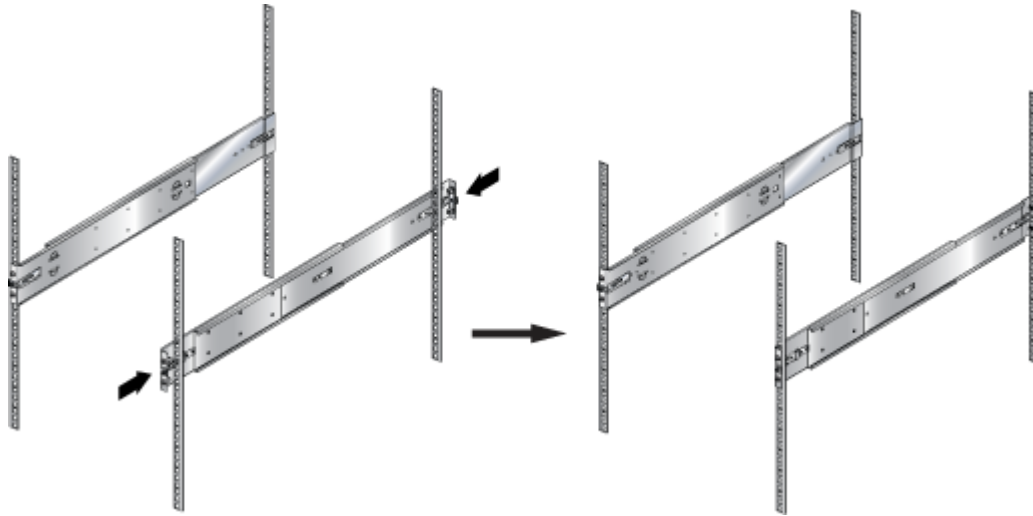

3.2 Mounting Ears Installation

Figure 3-4 displays the rack mounting ears, which secure the switch top to the rack. Attach the two rack mounting ears to each side of the switch. The inner side of each ear may include a latch to the locking mechanism that secures the ear to the rack. The two rack mounting ears are identical and will attach to the switch such that the securing screws are on the outside of the switch as shown.

Figure 3-4: Rack Mounting Ears

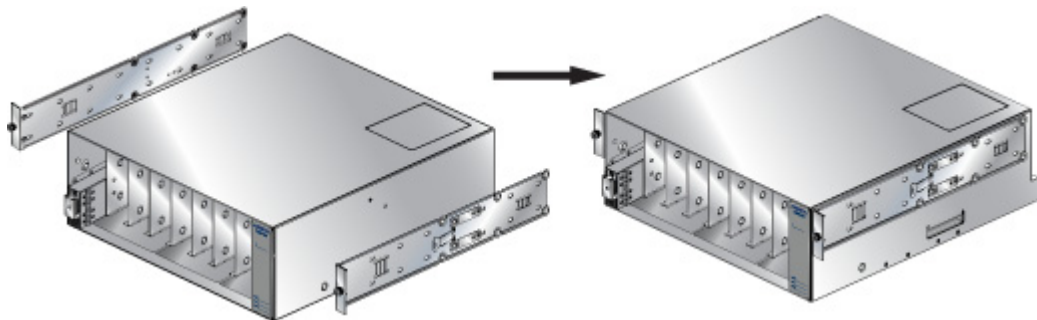

3.3 Switch Insertion into Rack

Use a forklift to raise and align the switch with the installed shelves and insert the rollers on the rack mount ears into the shelves' channels. Push and slide the switch into the rack to secure.

Note The rack mounting ears use only the top two rack units but you must allocate four rack units from the top of the shelves for the switch.

Figure 3-5: Inserting the Switch

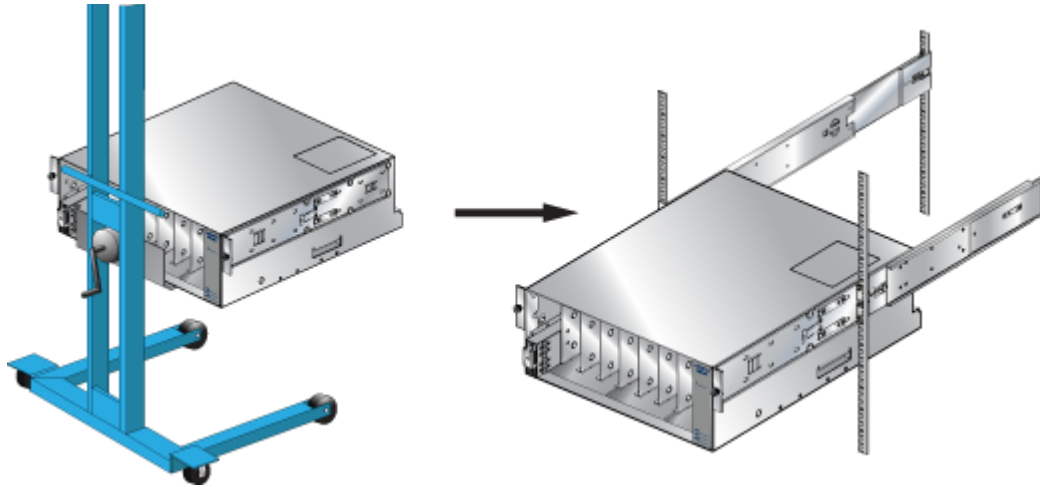
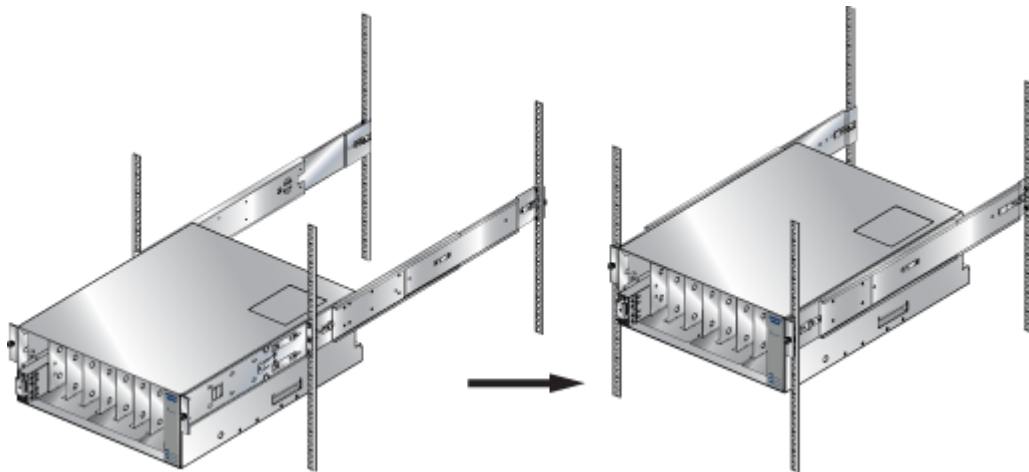

Figure 3-6: Securing the Switch



After completing the Four-Post Installation, proceed to [Chapter 4](#).

Powering the Modular Switch

Important! Installation of this equipment must comply with local and national electrical codes. If necessary, consult with the appropriate regulatory agencies and inspection authorities to ensure compliance.

Installation de cet équipement doit être conformes aux codes électriques locaux et nationaux. Si nécessaire, consulter les organismes de réglementation appropriés et des autorités de contrôle pour assurer la conformité.

The switch operates with multiple power supplies. Refer to [Table 1-1 on page 3](#) for information regarding your specific system. [Table 4-1](#) lists the quantity of modules each chassis can contain and the minimum operating requirements for each model.

Table 4-1 Power Supply Capacity and Requirements for 7368X4 Series Modular Switches

| Switch Model | Chassis Capacity (Power Supply Units) | Minimum Operating Requirements (non-redundant power) |
|--------------|---------------------------------------|--|
| DCS-7368X4 | 4 | 1 active circuit |

[Appendix D](#) displays the location of the power supplies on the rear panel of the switch. Unpopulated power supply bays must be covered using the appropriate “blank” for the switch.

This chapter includes sections that describe procedure for grounding and cabling power supplies. After completing the instructions for your switch, proceed to [Chapter 5](#).

Important! Read all installation instructions before connecting the system to the power source.

Lire toutes les instructions d'installation avant de brancher le système à la source d'alimentation.

- **Non-Redundant Configuration:** Provide power to the minimum required power inputs.
 - **Redundant Power Supply Configuration:** Connecting power to modules in excess of minimum requirements protects the switch against failed modules and can provide grid-level redundancy.
 - **Power down the Switch:** Remove all power cords from the power input sockets.
-

Important! This equipment must be grounded. Never defeat the ground conductor. This unit requires over-current protection.

Cet équipement doit être mis à la terre. Ne jamais modifier le conducteur de terre. Cet appareil nécessite de protection contre les surintensités.

4.1 Cabling the AC Power Supply

4.1.1 Grounding the Switch

After mounting the switch into the rack, connect the switch to the data center ground. [Figure 4-2](#) displays the location of the grounding pads located on the rear of the switch. It is recommended that you use a right-angle ground lug to attach the chassis ground wire. [Figure 4-2](#) displays the chassis ground wire attached to the switch and routed out for attachment to the data center ground.

Figure 4-1: Grounding Pad and ESD Grounding Pad Sockets



Important! Grounding wires and grounding lugs (M4 x 0.7) are not supplied. Wire size should meet local and national installation requirements. Commercially available 6 AWG wire is recommended for installations in the U.S.

À la terre et de mise à la terre fils cosses (M4 x 0.7) ne sont pas fournis. Calibre des fils doit satisfaire des exigences de l'installation locale et nationale. Disponible dans le commerce des câbles 6 AWG sont recommandé pour les installations aux États-Unis.

After the switch is grounded, ESD wrist straps can be grounded by connecting them to the ESD port on either the rear ([Figure 4-2](#)) or the front of the switch ([Figure 4-3](#)).

Figure 4-2: Grounding Pad and ESD Grounding Pad Sockets (Rear)

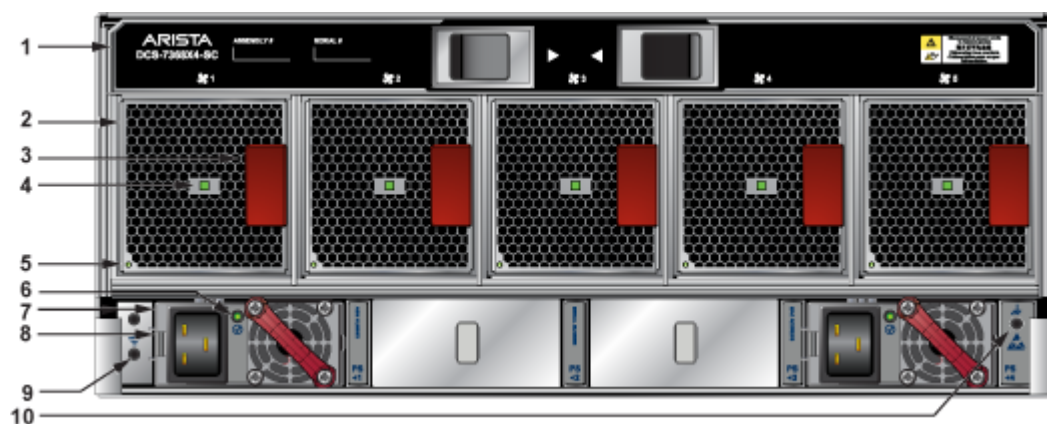

| | | | |
|---|-----------------------------------|----|----------------------------|
| 1 | Switch Card Module Release Handle | 2 | Fan |
| 3 | Fan Release Handle | 4 | Fan Installation Indicator |
| 5 | Fan Status LED | 6 | PSU Status LED |
| 7 | PSU | 8 | PSU Release Handle |
| 9 | Ground | 10 | ESD |

Figure 4-3: ESD Grounding Pad Sockets (Front)



| | | | |
|---|------------------------|---|--------------------------|
| 1 | Supervisor Module | 2 | Supervisor Ejector Latch |
| 3 | Linecard Ejector Latch | 4 | ESD |

4.1.2 Connecting Power Cables to an AC Power Supply

Figure 4-4 displays an AC power supply module, including the power input socket.

Figure 4-4: Power Input Sockets

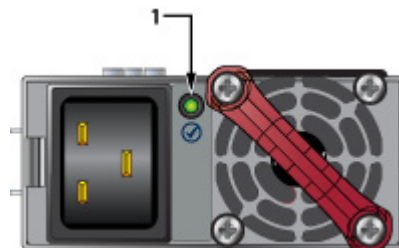

| | |
|---|-------------------------|
| 1 | Power Supply Status LED |
|---|-------------------------|

The power supplies require power cables that comply with IEC-320 C19 plug. The accessory kit provides 14 AWG, C19 to C20 power cables.

To insert a power cable:

Step 1 Pull the retaining clip back on each power input socket.

Note The retaining clip is optional (if provided).

Step 2 Plug the power cables into the sockets.

Step 3 Adjust the retaining clips if needed for your power cords (if retaining clip was provided).

Step 4 Push the retaining clip back down over the cable (if retaining clip was provided).

Connecting Serial and Management Cables

5.1 Connecting Supervisor Cables

Supervisor module contains the console, management, and USB ports. [Figure 5-1](#) displays port locations on 7368X4 Series Modular switch supervisors.

Figure 5-1: Supervisor Ports



| | | | |
|---|---------------------------|---|----------|
| 1 | Console Port (Serial) | 2 | USB Port |
| 3 | Ethernet Management Ports | | |

- **Console (Serial) Port:** Connect to a PC with RJ-45 to DB-9 serial adapter cable. Default switch settings include:
 - 9600 baud
 - No flow control
 - 1 stop bit
 - No parity bits
 - 8 data bits
- **Ethernet management port:** Connect to 10/100/1000 management network with RJ-45 cable.
- **Ethernet management port (optical):** Connect to 1 Gbit management network with SFP connector module and cable.

Figure 5-2: SFP Port Module Insertion

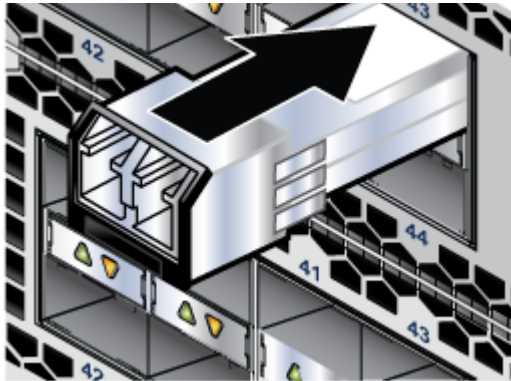

Connect cables as required to line card module ports. Supervisor and line card module ejectors on the front of the chassis assist with cable management.

Caution Excessive bending can damage interface cables, especially optical cables.

Flexion excessive peut endommager les câbles d'interface, en particulier les câbles optiques.

- **USB Port:** May be used for software or configuration updates.

5.2 Connecting Linecard Modules and Cables

Install required QSFP28, QSFP-DD, and OSFP optic modules in linecard module ports.

Note In some devices, adjacent QSFP ports may require you to rotate the module for insertion.

Figure 5-3: Optical Module Insertion

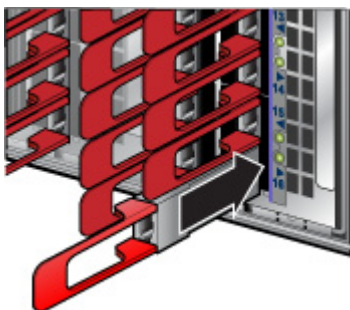

Note For more information about supported optical transceivers, refer to <https://www.arista.com/assets/data/pdf/Transceiver-Guide-V04.pdf>.

Caution Excessive bending can damage interface cables, especially optical cables.

Configuring the Switch

Arista switches ship from the factory in Zero Touch Provisioning (ZTP) mode. ZTP configures the switch without user intervention by downloading a startup configuration file or a boot script from a location specified by a DHCP server. To manually configure a switch, ZTP is bypassed. The initial configuration provides one username (*admin*) accessible only through the console port because it has no password.

When bypassing ZTP, initial switch access requires logging in as *admin*, with no password, through the console port. Then you can configure an *admin* password and other password protected usernames.

This manual configuration procedure cancels ZTP mode, logs into the switch, assigns a password to *admin*, assigns an IP address to the management port, and defines a default route to a network gateway.

Step 1 Provide power to the switch (Chapter 4).

Step 2 Connect the console port to a PC (Chapter 5).

As the switch boots without a *startup-config* file, it displays this message through the console:

```
The device is in Zero Touch Provisioning mode and is attempting to
download the startup-config from a remote system. The device will not
be fully functional until either a valid startup-config is downloaded
from a remote system or Zero Touch Provisioning is cancelled. To cancel
Zero Touch Provisioning, login as admin and type 'zerotouch cancel'
at the CLI.
```

```
localhost login:
```

Step 3 Log into the switch by typing **admin** at the login prompt.

```
localhost login:admin
```

Step 4 Cancel ZTP mode by typing **zerotouch cancel**. *IMPORTANT: This step initiates a switch reboot.*

```
localhost>zerotouch cancel
```

Step 5 After the switch boots, log into the switch again by typing **admin** at the login prompt.

```
Arista EOS
localhost login:admin
Last login: Fri Mar 15 13:17:13 on console
```

Step 6 Enter global configuration mode.

```
localhost>enable
localhost#config
```

Step 7 Assign a password to the *admin* username with the **username secret** command.

```
localhost(config)#username admin secret pxq123
```

Step 8 Configure a default route to the network gateway.

```
localhost(config)#ip route 0.0.0.0/0 192.0.2.1
```

Step 9 Assign an IP address (**192.0.2.8/24** in this example) to an Ethernet management port.

```
localhost(config)#interface management 1/1
localhost(config-if-Ma1/1)#ip address 192.0.2.8/24
```

Step 10 Save the configuration by typing **write memory** or **copy running-config startup-config**.

```
localhost#copy running-config startup-config
```

When the management port IP address is configured, use this command to access the switch from a host, using the address configured in step 9:

```
ssh admin@192.0.2.8
```

Refer to the **Arista Networks User Manual** for complete switch configuration information.

Status Indicators

A.1 Supervisor Module

The supervisor displays switch component status and contains Ethernet management and console ports. [Appendix C](#) displays the supervisor location on the switch.

The supervisor provides one serial console port, two Ethernet management ports (one RJ-45, one optical), and one USB port. Four LEDs on the top edge report system status, fan status, power status, and switch module status. [Figure A-1](#) shows the supervisor module status LEDs.

Figure A-1: Supervisor Module Status LEDs



| | | | |
|---|-------------------------|---|------------------------|
| 1 | System Status LED | 2 | Fan Status LED |
| 3 | Power Supply Status LED | 4 | Switch Card Status LED |

Supervisor Status LEDs

[Table A-1](#) interprets the states of the LED indicators on the supervisor module. When error conditions are indicated, refer to LEDs on the specified components to determine the condition's source.

Table A-1 Supervisor LED States⁽¹⁾

| LED Name | LED State | Module State |
|--------------|-----------|---|
| Power Supply | Green | All powered modules are operating normally. |
| | Red | At least one module has failed. |

Table A-1 Supervisor LED States⁽¹⁾ (Continued)

| LED Name | LED State | Module State |
|-------------|-----------|---|
| System | Green | All linecards are operating normally. |
| | Red | At least one linecard has failed. |
| Switch Card | Green | Module is operating normally. |
| | Red | Module has failed. |
| Fan | Amber | At least one fan is missing or has failed. |
| | Green | All modules are operating normally. |
| | Red | There are insufficient functional fans installed in the switch. |

(1): If all Status LEDs are OFF, check the following: power feeds are live, power supplies are installed, Switch Card is properly seated, and Supervisor is properly seated. The system will not power up unless all four of these conditions are valid.

A.2 Line Card Module Indicators

Each line card module provides one status LED plus LEDs for each port on the card. The figures in [Appendix E](#) indicate the location of the LEDs on each line card. [Figure A-2](#) displays the status LED and Port LEDs on the DCS-7368-16C-LC line card. Arrows indicate the port status being displayed by the corresponding port status LED.

Figure A-2: Linecard Status LEDs (DCS-7368-16C-LC)

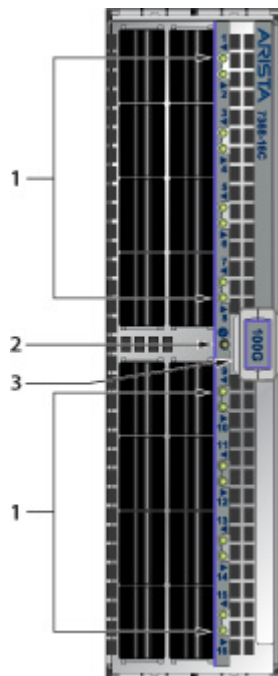

- 1 Linecard Port LEDs
- 2 Linecard Status LED
- 3 Linecard Ejector Latch

The Line Card Status LED is in the center of the DCS-7368-16C-LC. [Table A-2](#) interprets the states of the Status LED. [Table A-3](#) interprets the port LED states.

Table A-2 Linecard Status LED States

| LED State | Status |
|-----------|---------------------------------------|
| Off | Line card not inserted. |
| Green | Line card operating normally. |
| Amber | Line card administratively shut down. |
| Red | Line card has failed. |

Table A-3 Linecard Port LED States

| LED State | Status |
|-----------|-------------------------------|
| Off | Port link is down. |
| Green | Port link is up. |
| Yellow | Port is disabled in software. |

A.3 Fan Module Status Indicators

The fan modules are inserted into the switch card module. Each switch contains one switch card and five fan modules. [Appendix D](#) displays the rear panel of the switch covered by this guide. The fan module indicator is displayed in [Figure A-3](#). The fan handle color indicates the airflow direction. All fan modules must have the same color handle.

Note The orientation of the fan module as inserted in the switch may be different from the one shown.

Figure A-3: Fan Status LEDs



- | | | | |
|---|--------------------|---|----------------------------|
| 1 | Fan Release Handle | 2 | Fan Installation Indicator |
| 3 | Fan Status LED | | |

The **fan installation indicator** is green when the fan module is properly installed or red when the module is not fully installed. [Table A-4](#) interprets the states of the Fan Status LED.

Table A-4 Fan and Fabric Status LED States

| LED State | Status |
|-----------|---|
| Off | The module is inserted but not receiving power – it may not be properly seated. |

Table A-4 Fan and Fabric Status LED States (Continued)

| LED State | Status |
|-----------|-----------------------------------|
| Green | The module is operating normally. |
| Red | The module has failed. |

A.4 Power Supply Status Indicators

Power Supply LEDs are on power supply modules. The rear panel contains power supply modules for all switches. [Appendix D](#) (rear panels) displays the position of these LEDs on each switch.

[Figure A-4 on page 24](#) display a power supply module.

The power supply handle indicates the power supply fan direction. Verify the airflow direction of all modules have the same color handles.

Figure A-4: Power Supply

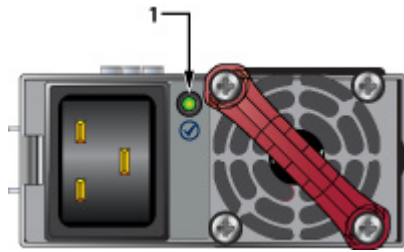

1 Power Supply Status LED

[Table A-5](#) interprets the states of the Power Supply Status LED.

Table A-5 Power Supply Status

| LED | Status |
|----------------|--|
| Green | Power Supply module operating normally. |
| Off | No AC power to the module. |
| Red | Module has faulted. |
| Blinking Green | PSU has AC power but hasn't been enabled by the system - indicates that either the power supply or the Switch Module isn't fully inserted. |

Parts List

Each switch provides an accessory kit that contains parts that are required to install the switch into a four-post rack. The following sections list the installation parts provided by the accessory kit.

B.1 Parts Used in All Configurations

| Quantity | Description |
|--|---------------------------------------|
| One for each AC power supply module supplied with switch | Power cables: 14 AWG, C19-C20 |
| One | RJ-45 Patch Panel Cables, 2 meters. |
| One | RJ-45 to DB9 Adapter Cable, 2 meters. |

Warning All provided power cables are for use only with Arista products.

警告

すべての電源コードは提供する製品で使用するためだけを目的としている。

電源コードの他の製品での使用の禁止

Aristaが提供するすべての電源コードは、Aristaの製品でのみ使用してください。

B.2 Four-Post Rack Mount Parts

| Quantity | Description |
|----------|---------------|
| 2 | Mounting Ears |
| 1 | Left shelf. |
| 1 | Right shelf. |

Figure B-1: Four-Post Rack Mount Parts

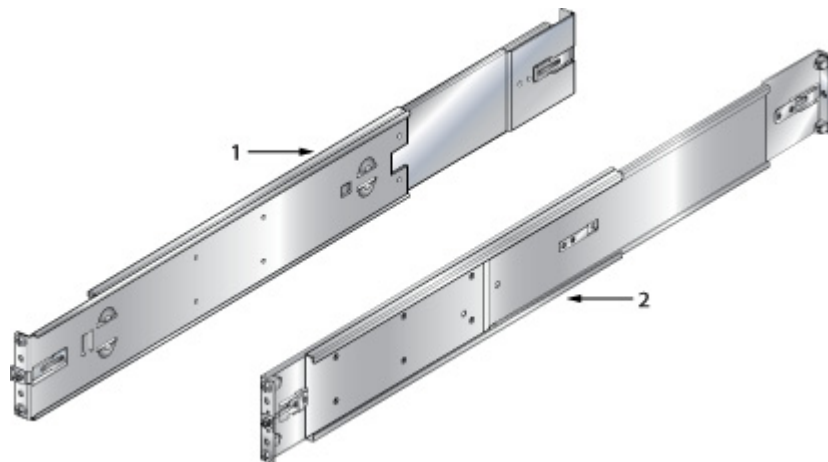

1 Left Shelf

2 Right Shelf

Front Panels

This appendix displays the front panel of all switches covered by this guide.

DCS-7368X4 Front Panel (fully populated)



- | | | | |
|---|------------------------|---|--------------------------|
| 1 | Supervisor Module | 2 | Supervisor Ejector Latch |
| 3 | Linecard Ejector Latch | 4 | ESD |

Rear Panels

This appendix displays the rear panel of all switches covered by this guide.

DCS-7368X4 Rear Panel

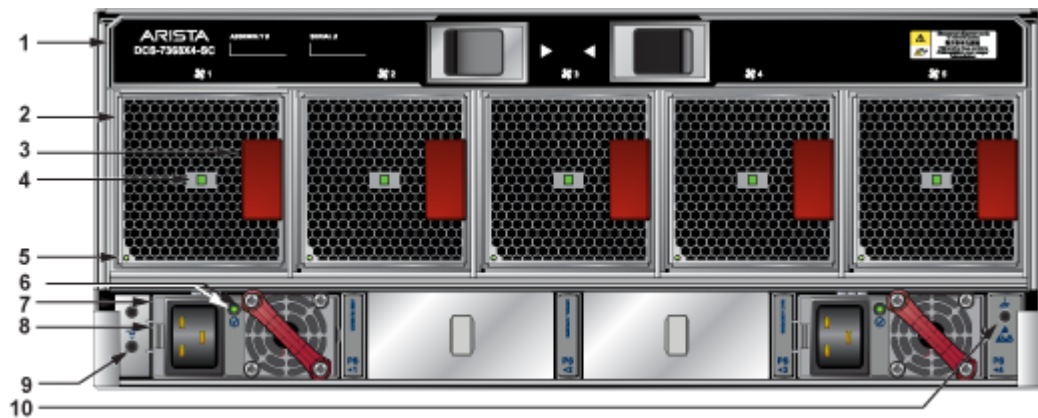

- | | | | |
|---|-----------------------------------|----|----------------------------|
| 1 | Switch Card Module Release Handle | 2 | Fan |
| 3 | Fan Module Release Lever | 4 | Fan Installation Indicator |
| 5 | Fan Status LED | 6 | PSU Status LED |
| 7 | PSU | 8 | PSU Release Handle |
| 9 | Ground | 10 | ESD |

Appendix E

Line Cards

This appendix displays the Line cards supported by modular switches covered by this guide.

DCS-7368-16C-LC

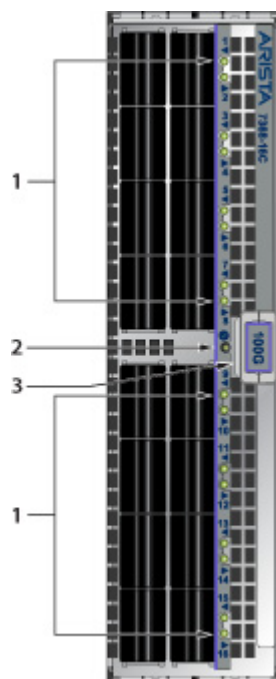

- 1 Linecard Port LEDs
- 3 Linecard Ejector Latch

- 2 Linecard Status LED

Maintenance and Field Replacement

Note Follow ESD protection protocols while handling components of the switch during maintenance operations.

F.1 Switch Card Module

The switch card module is accessible from the rear of the switch as shown in [Appendix D](#). Refer to [Figure F-1](#) for more details on the removal and replacement of the switch card module.

Figure F-1: Switch Card Module Maintenance



1 Switch Card Release Handle

2 Switch Card Release Lever

The module includes lock-levers that secure it to the chassis. The module and the lock levers are easily damaged by improperly removing, inserting, or handling. Use caution while lifting or moving the module after it is removed from the chassis.

F.1.1 Removing Switch Card Module

Follow the steps listed below to remove the switch card module from the switch chassis.

Step 1 Ground yourself with an ESD wrist strap.

Step 2 Move the release handle down.

Step 3 Pinch the release levers towards the center to unlock the module from the chassis.

Step 4 Carefully, remove the switch card module from the chassis while supporting it through the process.

F.1.2 Inserting Switch Card Module

The module insertion process is the inverse of the removal procedure. Follow the steps listed below to insert the switch card module into a chassis.

- Step 1** Align the switch card module with the rails in the chassis for insertion.
- Step 2** Slide the module gently into the chassis until you feel a little resistance towards the end. The switch card module will extend just a little bit outside the chassis.
- Step 3** Pinch the release levers towards the center and continue to push the module in until it is flush with the chassis and let go of the release levers.
- Step 4** Try moving the module out gently, without engaging the release levers. The module will not move if it is seated correctly.
- Step 5** Return the release handle to its locked position (up).

Note

Descriptions for the removal and replacement of power supplies and fans are for a representative power supply or fan. Locations of status indicator LEDs may differ. Refer to the front and rear panel illustrations of your device to locate the appropriate LED.

F.2 Power Supplies

The power supplies are accessible from the rear of the switch as shown in [Appendix D](#). Refer to [Figure F-2](#) for more details on the removal and replacement of a power supply unit.

The following steps are required when removing power supplies from a switch.

F.2.1 Removing a Power Supply

- Step 1** Ground yourself with an ESD wrist strap.
- Step 2** Power down the power supply to be removed by disconnecting the AC power cable.
- Step 3** Push the power supply release handle and remove the power supply ([Figure F-2](#)).

Figure F-2: Remove power supply

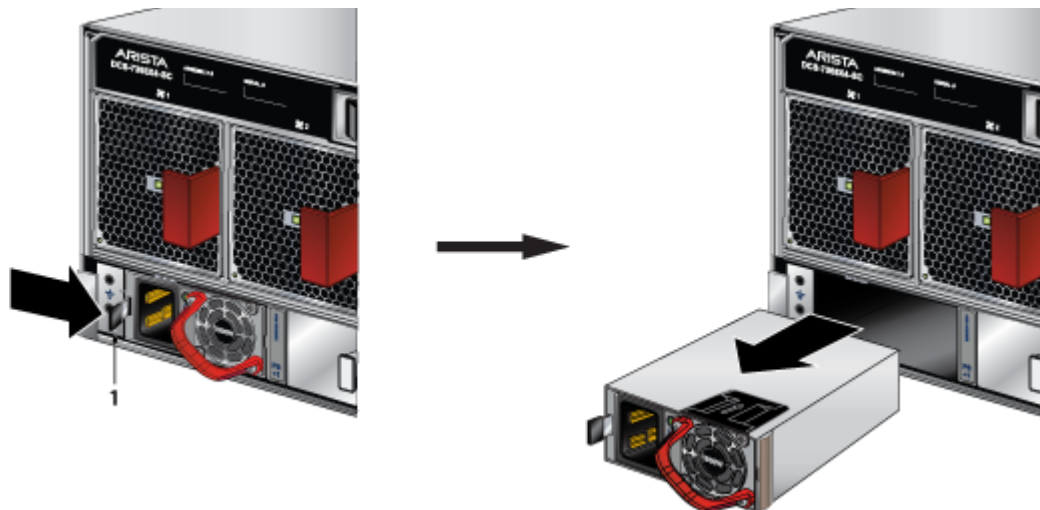

1 PSU Release Handle

F.2.2 Installing a Power Supply

You must make space for installing the power supply by removing an existing one (Section F.2.1).

Step 1 Remove the replacement power supply from its packaging.

Step 2 Slide the new power supply into the empty slot.

Step 3 Slide the new power supply into the switch until the power supply is fully seated and the release handle snaps into place.

Step 4 Connect the power cord to the power supply.

Step 5 Verify the LED(s) on the power supply.

Note

The Power Supply status LED should be a steady green for normal operation.

Step 6 Verify the new power supply operation by issuing the **show environment power** command.

```
switch#show environment power
```

The output of the command will list the power supplies in operation and should include the one you replaced.

F.3 Fan Modules

The fan modules are accessible from the rear of the switch as shown in Appendix D. Refer to Figure F-3 for more details on the removal and replacement of a fan module.

F.3.1 Removing a Fan Module

The following steps are required when removing or replacing fans from a switch.

Step 1 Ground yourself with an ESD wrist strap.

Step 2 Push the fan module release lever and slide the fan module out of the switch (Figure F-3).

Figure F-3: Removing fan module

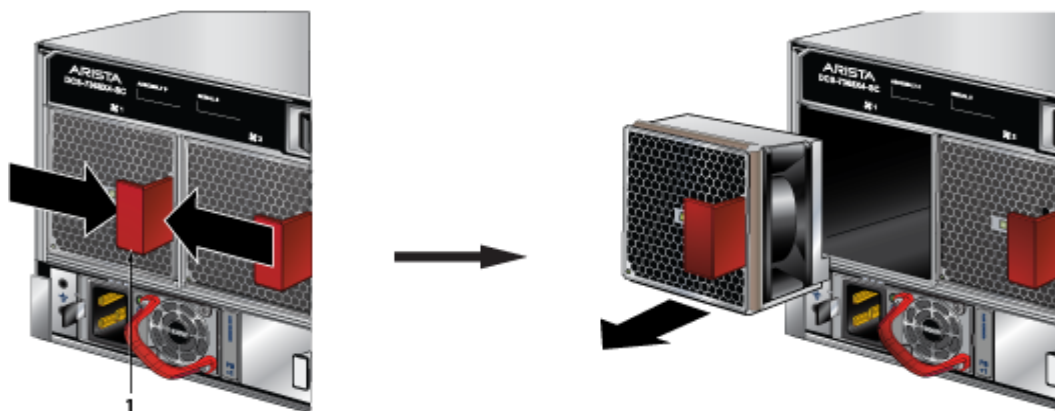

1 Fan Module Release Lever

F.3.2 Installing a Fan Module

You must make space for installing the fan module by removing an existing one ([Section F.3.1](#)).

Step 1 Remove the replacement fan from its packaging.

Step 2 Slide the new fan module into the switch until the module is fully seated and the release lever snaps into place.

The fan installation indicator will be green when the fan is installed and seated correctly.

Step 3 Verify that the fan module is working normally.

Note The fan module status LED should be a steady green for normal operation.

F.4 Supervisor Module

The supervisor module is accessible from the front of the switch as shown in [Appendix C](#). Refer to [Figure F-4](#) for more details on the removal and replacement of a supervisor module.

Note Supervisors are hot-swappable. The switch will reboot when the replacement supervisor powers up.

Figure F-4: Supervisor Module Maintenance



F.4.1 Removing Supervisor Module

Perform the following steps to remove the module.

Step 1 Put on a grounded ESD strap.

Step 2 Lift the supervisor module ejector latch and move the latch down to release the supervisor module.

Step 3 Gently remove the supervisor module by pulling outwards.

F.4.2 Installing Supervisor Module

You must make space for installing the module by removing an existing one ([Removing Supervisor Module](#)). Perform the following steps to install the module.

- Step 1** Put on a grounded, anti-static ESD strap.
- Step 2** Unpack the supervisor module to be installed.
- Step 3** Slide supervisor module into slot.
- Step 4** Raise the ejector handle and latch it into place.

Verify that the module is operating normally.

F.5 Linecards

The linecards are accessible from the front of the switch as shown in [Appendix C](#). The linecards are hot-swappable. You must take into account that the linecard you are inserting is compatible with the switch and the linecard that you are replacing. Refer to [Figure F-5](#) for more details on the removal and replacement of a linecard module.

Figure F-5: Linecard Module Maintenance

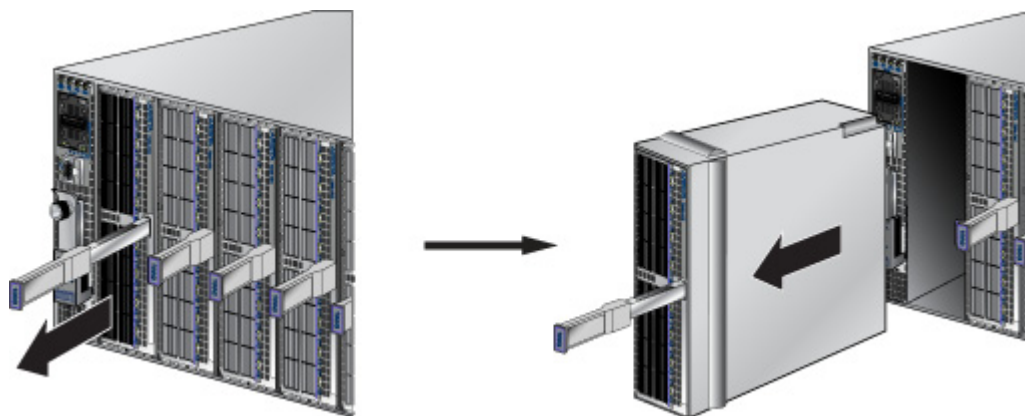

F.5.1 Removing Linecard

Perform the following steps to remove a linecard.

- Step 1** Put on a grounded, anti-static ESD strap.
- Step 2** Use the ejector handle or lever in the middle of the linecard to release it from the chassis.
- Step 3** Slide the linecard gently out of the slot.

F.5.2 Installing Linecard

You must make space for installing the linecard by removing an existing one ([Removing Linecard](#)) from a linecard slot available on the switch.

- Step 1** Put on a grounded, anti-static ESD strap.
- Step 2** Unpack the linecard to be installed.
- Step 3** Slide the linecard gently into the slot.

Step 4 Use the ejector handle of the linecard to seat the linecard into the chassis.

Step 5 Verify that the linecard is operating normally (Table A-3 on page 23).

F.6 Optical Transceivers

For more information about supported optical transceivers and how to remove or install them, refer to <https://www.arista.com/assets/data/pdf/Transceiver-Guide-V04.pdf>.

Appendix G

Regulatory Model Numbers

This appendix lists the regulatory model numbers (RMNs), where applicable, for the product models for the switches described in this document.

Table G-1 Regulatory Model Numbers and Product Numbers

| Regulatory Model Number (RMN) | Product Number(s) |
|-------------------------------|-------------------|
| AN1722 | DCS-7368X4 |

Appendix H

Taiwan RoHS Information

This appendix provides Taiwan RoHS information for switches covered by this guide.

For Taiwan BSMI RoHS Table, go to <https://www.arista.com/assets/data/pdf/AristaBSMIroHS.pdf>.

