

ARISTA

QUICK START GUIDE

7200S Series

ZTX MSS Appliance

ZTX-7250S-16S-F



Headquarters	Support	Sales
5453 Great America Parkway Santa Clara, CA 95054 USA +1-408-547-5500	+1-408-547-5502 +1-866-476-0000	+1-408-547-5501 +1-866-497-0000
www.arista.com/en/	support@arista.com	sales@arista.com

© Copyright 2024 Arista Networks, Inc. All rights reserved. The information contained herein is subject to change without notice. The trademarks, logos, and service marks ("Marks") displayed in this documentation are the property of Arista Networks in the United States and other countries. Use of the Marks is subject to the Arista Networks Terms of Use Policy, available at www.arista.com/en/terms-of-use. Use of marks belonging to other parties is for informational purposes only.

Contents

- Chapter 1: Overview..... 1**
 - 1.1 Scope..... 1
 - 1.2 Receiving and Inspecting the Equipment..... 1
 - 1.3 Installation Process..... 1
 - 1.4 Safety Information..... 2
 - 1.5 Obtaining Technical Assistance..... 2
 - 1.6 Specifications..... 3

- Chapter 2: Preparation..... 4**
 - 2.1 Site Selection..... 4
 - 2.2 Tools and Parts Required for Installation..... 5
 - 2.3 Electrostatic Discharge (ESD) Precautions..... 5

- Chapter 3: Rack Mounting the Device..... 6**
 - 3.1 Four-post Rack Mount..... 6
 - 3.1.1 Attaching Mounting Brackets to the Chassis..... 7
 - 3.1.2 Assembling the Rails onto the Equipment Rack..... 8
 - 3.1.3 Inserting the Device to the Rack..... 10
 - 3.2 Two-post Rack Mount (Optional)..... 10
 - 3.2.1 Attaching Mounting Brackets to the Chassis (Two-post)..... 11
 - 3.2.2 Inserting the Device into the Rack..... 12

- Chapter 4: Status Indicators..... 14**

- Chapter 5: Cable the Device..... 15**
 - 5.1 Grounding the Device..... 15
 - 5.2 Connecting Power Cables..... 16
 - 5.2.1 AC Power Supplies..... 16
 - 5.3 Connecting Serial and Management Cables..... 17

- Chapter 6: Configuring the Device..... 18**

- Chapter 7: Parts List..... 20**

- Chapter 8: Front Panel..... 21**
 - 8.1 ZTX-7250S-16S-F..... 21

- Chapter 9: Rear Panel..... 22**
 - 9.1 ZTX-7250S-16S-F..... 22

Chapter 10: Interface Configuration and Behavior.....	23
10.1 ZTX-7250S-16S-F.....	23
Chapter 11: LCD Operation.....	27
Appendix A: Regulatory Model Numbers.....	30
Appendix B: RoHS Information.....	31

Overview

This guide is intended for network professionals who need to install the Arista 7200 S-Series ZTX MSS Appliance.

The section reviews the following topics:

- [Scope](#)
- [Receiving and Inspecting the Equipment](#)
- [Installation Process](#)
- [Safety Information](#)
- [Obtaining Technical Assistance](#)
- [Specifications](#)

1.1 Scope

This section lists the covered devices in this guide:

- ZTX-7250S-16S-F



CAUTION: Only qualified or trained personnel should install, service, or replace this equipment.

Seul le personnel qualifié doit installer, service, ou remplacer cet équipement.

1.2 Receiving and Inspecting the Equipment

Upon receiving the device, inspect the packaging and record if there is any external damage. Retain the packing material if you suspect any part of the shipment is damaged; the carrier might need the packing material to inspect.

If the packaging is not damaged during transit, unpack each box carefully. Ensure that all accessories are packed in the same box as the device.

Review the packing list that comes with the networking device to assure you have received all the items listed. Refer to the [Parts List](#) to verify that all components are present.

1.3 Installation Process

This section describes the steps for installing and using the ZTX MSS Appliance in a Campus or Data Center environment.

1. Select and prepare the installation site. ([Site Selection](#))
2. Assemble the installation tools listed. ([Tools and Parts Required for Installation](#))
3. Attach the mounting brackets and install the device in an equipment rack. ([Rack Mounting the Device](#))
4. Connect the device to the power source, console cables, and management network. ([Cable the Device](#))
5. Configure the ZTX MSS Appliance. ([Configuring the Device](#))

1.4 Safety Information

Refer to the Arista Networks document. Safety Information and Translated Safety Warnings are available at <https://www.arista.com/en/support/product-documentation>.



Important:

Class 1 laser product: This product has provisions for installing Class 1 laser transceivers that provide optical coupling to the communication network. After installing a Class 1 laser product, the equipment is now a Class 1 laser product. The customer is responsible for selecting and installing the Class 1 laser transceiver and for ensuring that the Class 1 AEL (allowable emission limit) per EN/IEC 60825, CSA E60825-1, and Code of Federal Regulations 21 CFR 1040 is not exceeded after the laser transceiver has been installed. Do not install laser products whose class rating is greater than 1. Refer to all safety instructions that accompany the transceiver before installation. Only Class 1 laser devices certified for use in the country of installation by the cognizant agencies are to be utilized in this product. The ultimate disposal of this product should be by all applicable laws and regulations.

Produit laser de classe 1: Ce produit a des dispositions pour installer des émetteurs-récepteurs de laser de classe 1 qui offre de couplage au réseau de communication optique. Une fois un produit laser de classe 1 est installé, l'équipement est un produit laser de classe 1 (Appareil à laser de Classe 1). Le client est responsable pour sélectionner et installer l'émetteur/récepteur de laser de classe 1 et pour assurer que la classe 1 AEL (limite d'émission admissible) par EN/IEC 6-825, CSA E60825-1, et Code des règlements fédéraux 21 CFR 1040 ne soit pas dépassée après avoir installé l'émetteur/récepteur de laser. Ne pas installer des appareils à laser dont la cote de classe est supérieure à 1. Voir toutes les consignes de sécurité qui ont accompagné l'émetteur-récepteur avant l'installation. Seuls appareils laser de classe 1 certifiés pour une utilisation dans le pays d'installation par l'organisme compétent doivent être utilisées dans ce produit.



Important:

DO NOT open the device case. There are NO user-serviceable parts inside. Entrust any repair to a qualified technician.

N'ouvrez PAS le boîtier du appareil. Il n'y a AUCUNE pièce réparable par l'utilisateur à l'intérieur. Confiez toute réparation à un technicien qualifié.

1.5 Obtaining Technical Assistance

Any customer, partner, reseller, or distributor holding a valid Arista Service Contract can obtain technical support in any of the following ways:

- **Email:** support@arista.com

Include a detailed problem description and the "show tech-support" output.

- **Web:** <https://www.arista.com/en/support>

The support portal on our website allows you to create support cases. You can also download the most current software and documentation and view FAQs, Knowledge Base articles, Security Advisories, and Field Notices.

- **Phone:** +1 866-476-0000 or +1 408-547-5502

1.6 Specifications

This section lists the specifications of the Arista 7200 S-Series ZTX MSS Appliance.

Table 1: Dimensions and Weights

MSS Appliance	Size (W x H x D)	Weight
ZTX-7250S-16S-F	17.32 x 3.46 x 20.47 inches (440 x 88 x 520 mm)	29.98 lbs (13.6 kg)

Table 2: Operating and Storage Temperature

MSS Appliance	Operating Temperature	Storage Temperature	Operating Altitude	Relative Humidity
ZTX-7250S-16S-F	32° to 104°F (0° to 40°C)	-13° to 158°F (-25° to 70°C)	0 to 10,000 feet (0 to 3048 meters)	5 to 95% (non-condensing)

Table 3: Power Input

MSS Appliance	Power Source	Input Power Rating
ZTX-7250S-16S-F	AC Power	100-240VAC, 10-5A, 50/60 Hz

Table 4: Power Draw

MSS Appliance	Power Draw (Typical/Maximum)	Supported Power Supply
ZTX-7250S-16S-F	200W/750W	PWR-861-AC-RED

Table 5: System Configurations

MSS Appliance	Airflow	Power Supply	Fan	Fan Type
ZTX-7250S-16S-F	Front to rear	2	3+1	FAN-7202-RED

Preparation

This section describes the initial set up and preparation for installing the ZTX MSS Appliance.

The following topics are covered in this section:

- [Site Selection](#)
- [Tools and Parts Required for Installation](#)
- [Electrostatic Discharge \(ESD\) Precautions](#)

2.1 Site Selection

The following criteria should be considered when selecting a site to install the device in a Data Center environment:

- **Temperature and Ventilation:** For proper ventilation, install the ZTX MSS Appliance with ample airflow to the front and back of the device.



Important: To prevent the device from overheating, do not operate it in an area where the ambient temperature exceeds 104°F (40°C).

Pour empêcher l'interrupteur de surchauffe, ne pas utiliser il dans une zone où la température ambiante est supérieure à 104°F (40°C).

- **Airflow Orientation:** The fans and PSUs determine the airflow direction through the device. The color of the visible handles or labels indicates the airflow direction.
- **Red Handle:** The red handle represents the air exit module. The following figure shows the airflow direction through the device with an air exit module.

Figure 2-1: Air Exit Modules

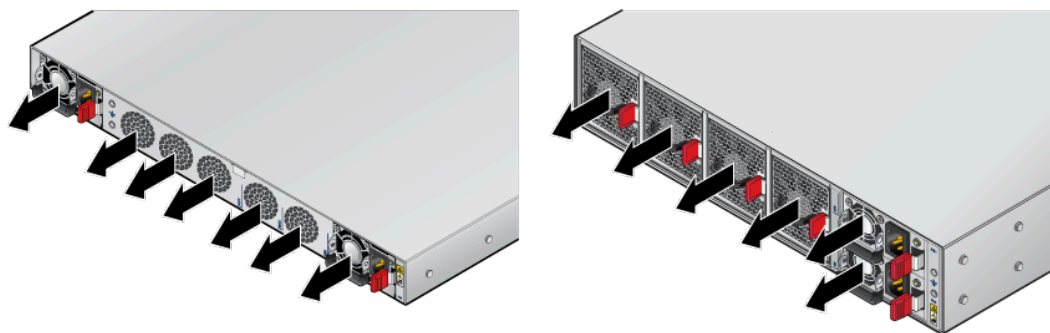

Orient the device so airflow goes from the cooler to the hotter aisle.

- **Rack Space:** Install the device in a 19" rack or cabinet. The accessory kit provides mounting brackets for two-post and four-post racks.

When mounting the device in a partially filled rack, load the rack from bottom to top, with the heaviest equipment at the bottom. If this device is the only item in the rack, load it at the bottom.

- **Power Requirements:** Each device and power supply model has different power requirements. For information regarding your specific system, refer to Specifications.

Refer to the [Cable the Device](#) section for power cable requirements.



Important: The power input plug-socket combination must be accessible at all times, as it provides the primary method of disconnecting power from the system.

La combinaison de la puissance-prise d'entrée doit être accessible en tout temps; Il fournit le principal moyen de coupure d'alimentation du système.



Important: All power connections must be removed to de-energize the device.

Toutes les connexions d'alimentation doivent être enlevées pour hors tension l'appareil.

- **Other Requirements:** Select a site where liquids or objects cannot fall onto the equipment and foreign objects are not drawn into the ventilation holes. Verify the following guidelines are met:
 - Clearance areas to the front and rear panels allow for unrestricted cabling.
 - All front and rear panel indicators can be easily read.
 - Power cords can reach from the power outlet to the connector on the rear panel.

2.2 Tools and Parts Required for Installation

Each product comes with an accessory kit containing the parts required to install. In addition to the accessory kit, the following tools are required to install the device:

Four-post Rack

- #1 and #3 Phillips head screwdrivers (this may differ based on supplied accessories)
- Screws or rack-mounting nuts and bolts

Two-post Rack

- #1 and #3 Phillips head screwdrivers (this may differ based on supplied accessories)
- Screws or rack-mounting nuts and bolts

The accessory kit should include screws for attaching the device to an equipment rack. When installing the device into an equipment rack with unthreaded post holes, nuts and bolts are also required to secure the device to the rack posts.

2.3 Electrostatic Discharge (ESD) Precautions

Observe these guidelines to avoid ESD damage when installing or servicing the device:



Important: DO NOT open the device case. There are no user-serviceable parts inside. Entrust any repair to a qualified technician.

N'ouvrez PAS le boîtier du routeur. Il n'y a AUCUNE pièce réparable par l'utilisateur à l'intérieur. Confiez toute réparation à un technicien qualifié.

- Assemble or disassemble the equipment only in a static-free work area.
- A conductive work surface (such as an anti-static mat) dissipates static charge.
- Wear a conductive wrist strap to dissipate static charge accumulation.
- Minimize handling of assemblies and components.
- Keep replacement parts in their original static-free packaging.
- Remove all plastic, foam, vinyl, paper, and other static-generating materials from the work area.
- Select tools that do not create ESD.

Rack Mounting the Device

This section provides instructions on how to rack mount the device.

The following table shows the list of supported rack mount brackets.

Table 6: Supported Rack Mount Brackets

MSS Appliance	Two-post Rack Mount	Four-post Rack Mount
ZTX-7250S-16S-F	KIT-2POST	KIT-4POST-NT (default) KIT-7101-RK KIT-7101-LD-RK

The following topics are covered in this section:

- [Four-post Rack Mount](#)
- [Two-post Rack Mount \(Optional\)](#)



Note: A four-post rack mount is recommended. Use the rack-mount parts included with the device for mounting.

3.1 Four-post Rack Mount

This section provides instructions for mounting the device in a four-post rack.

The device mounts onto a four-post rack by assembling two rails onto the rear posts, sliding the device onto the rails, and securing it to the front posts.

The installation kit provides the following four-post mounting parts:

- Two six-hole mounting brackets
- Two rail rods
- Two rail slides

The rail rods and rail slides assemble into two identical slide rails.

Each chassis side has attachment pins that align with bracket holes. Pin orientation is symmetric and equidistant, supporting bracket placements where the flange is flush with the front panel, flush with the rear panel, or not flush with either panel. Each bracket hole includes a key opening for placing the bracket flush with the chassis and then locking it into place.



Important: Attachment pins must engage at least five of the six bracket holes.

Goupilles de fixation doivent être lock au moins cinq des trous du six support.

The following figure displays proper bracket mount configuration examples for four-post mounting.

Figure 3-1: Bracket Mount Configuration for Four-post Rack Mount (Example)

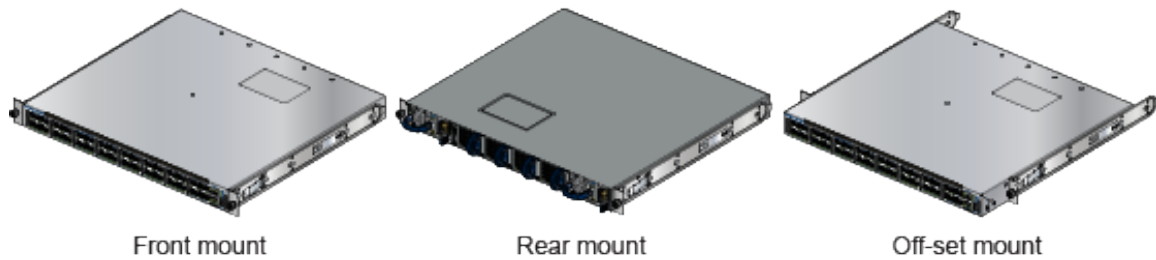

The following figure displays an example of an improper bracket mount configuration.

Figure 3-2: Improper Bracket Mount Configuration for Four-post Rack Mount (Example)

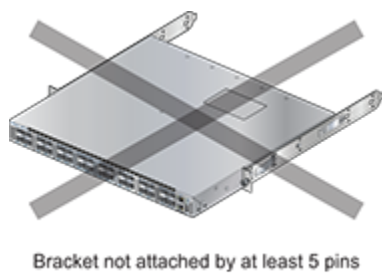

3.1.1 Attaching Mounting Brackets to the Chassis

This section describes the steps to attach mounting brackets to the chassis.

The following figure displays the front bracket alignment for mounting the device into a four-post rack.

Figure 3-3: Attaching the Mounting Brackets to the Device Chassis

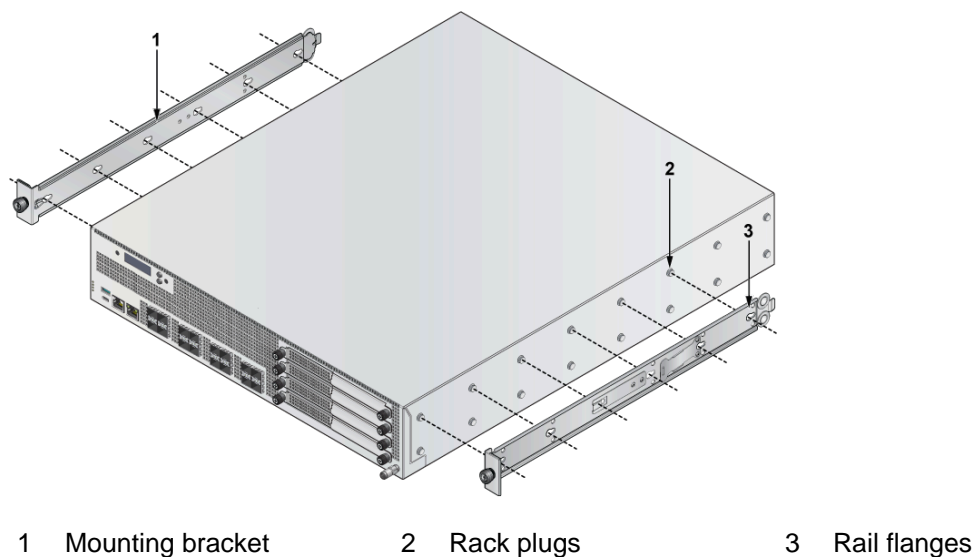

1 Mounting bracket

2 Rack plugs

3 Rail flanges

Figure 3-4: Aligning the Rack Plugs to the Bracket Clip

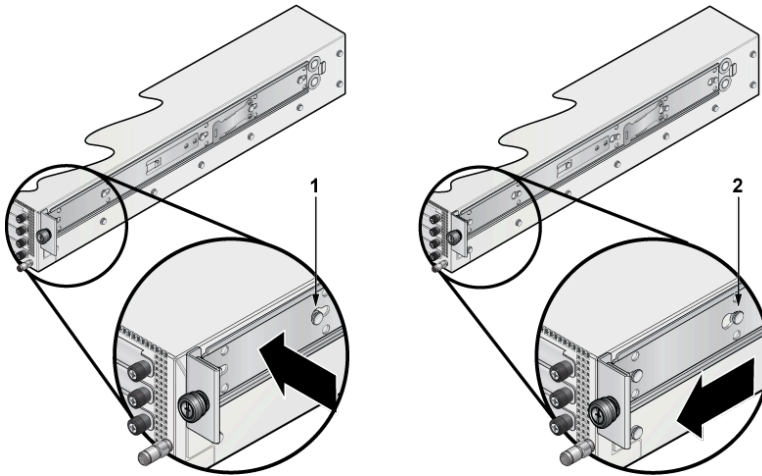

1 Bracket clip before it is locked in the specified place.

2 Bracket clip after it is locked in the specified place.

1. Align the mounting brackets with the attachment pins to obtain the desired mounting position.
2. Place the bracket flush to the chassis with the attachment pins protruding through the key openings.
3. Slide the bracket toward the front flange until the bracket clip locks with an audible click.

To remove the mounting bracket from the chassis, lift the front edge of the mounting bracket clip with a flat-head screwdriver and slide the bracket away from the front flange (opposite from the installation direction).

3.1.2 Assembling the Rails onto the Equipment Rack

Rail rods and rail slides assemble into two identical rails. Each rail connects a front post to a rear post. When installing the rails, the device slides through the rails into the rack. Each bracket includes a screw that attaches the device to the rail.

Each end of an assembled rail contains two rack plugs. Insert the plugs into rack slots to install the rails into a rack. When installing rails into rack posts with threaded or rounded holes, remove all plugs on both sides of the assembled rails and install them with bolts that fit the rack.

Figure 3-5: Attaching the Four-Post Mounting Brackets to the Device Chassis

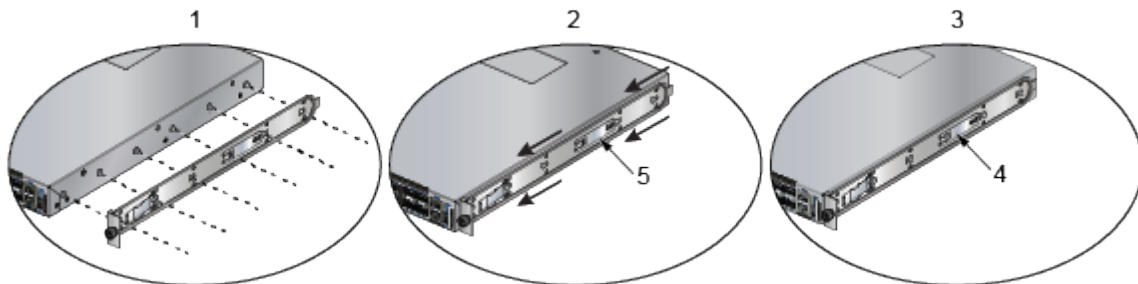

1 Attach rail slide to the device

2 Slide rail rod onto rail slide

3 Attach bracket clip

4 Bracket clip (attached)

5 Bracket clip (aligned)

1. Slide a rail rod into a rail slide until the rail clip makes an audible click.

The rail clip prevents the rail extension beyond the maximum supported distance between the front and rear rack posts.

Figure 3-6: Assembling the Rails

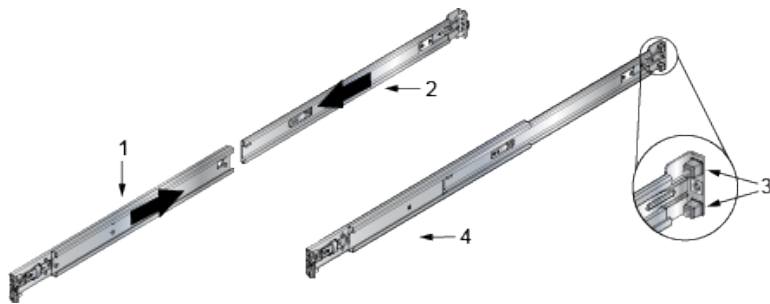

- | | |
|--------------|--------------------|
| 1 Rail slide | 3 Rack plugs |
| 2 Rail rod | 4 Rail (assembled) |

2. Attach the rail to the right rear rack post by inserting rod-end rack plugs into post slots. The slide assembly must be on the side of the post facing the device.
If the rack plugs were previously removed, use bolts to attach the rail to the rack.
3. Attach the slide end of the rail to the front post by extending the rail end past the post, then contracting the rail while guiding the rack plugs into the post.
4. Repeat **Step 1** through **Step 3** for the left posts. Ensure the rails are on the same horizontal level.

Figure 3-7: Attaching the Rails

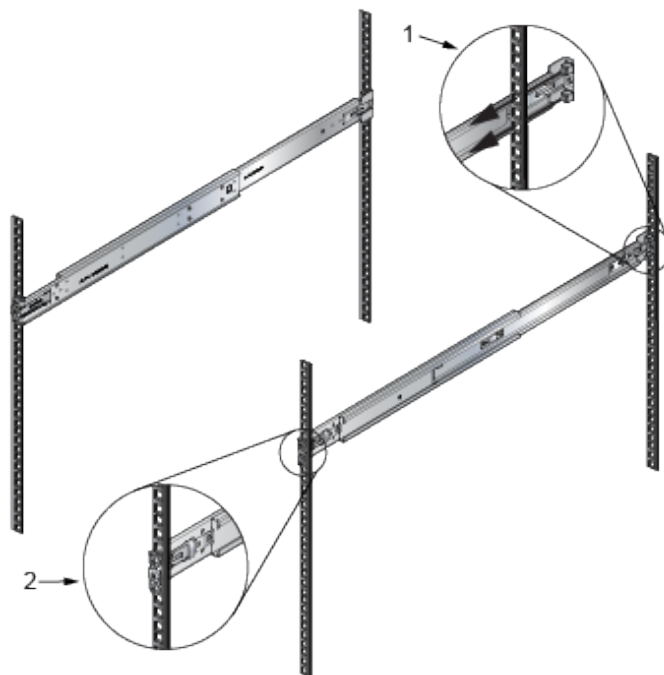

- | | |
|-----------|-----------|
| 1 Inset A | 2 Inset B |
|-----------|-----------|

3.1.3 Inserting the Device to the Rack

Slide the device into the rack after installing the rails. Each bracket includes a thumb screw that attaches the device to the rail.

1. Lift the device into the rack and insert the mounting brackets into the slide rails.

Figure 3-8: Inserting the Device onto the Rails

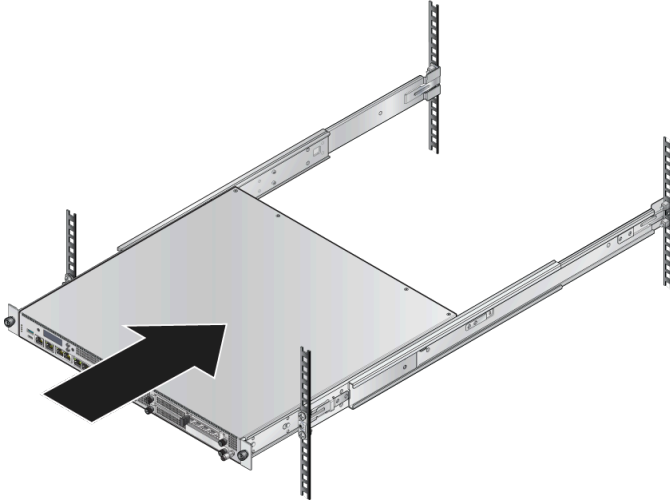

2. Slide the device on the rails toward the rear posts until the mounting bracket flanges are flush with the rail flanges attached to the rack posts.
3. Attach the bracket flanges to the rack post using the quick-release thumb screws supplied with the brackets.

Figure 3-9: Attaching the Device to the Rack Posts

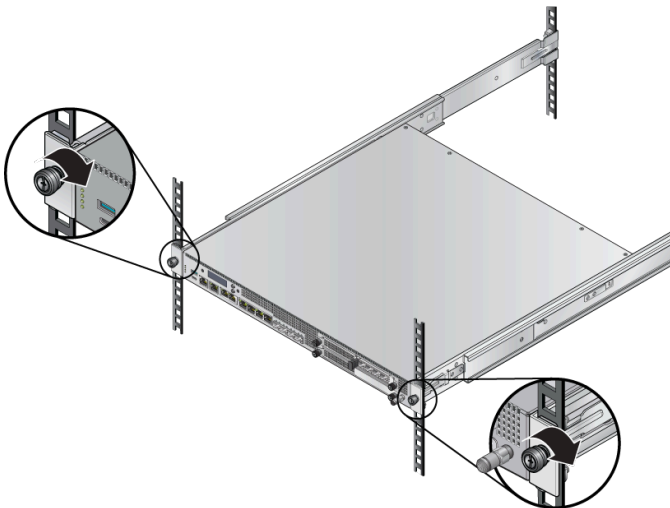

After completing the four-post rack mount, proceed to [Cable the Device](#) section.

3.2 Two-post Rack Mount (Optional)

This section provides instructions for mounting the device in a two-post rack.

To mount the device onto a two-post rack, assemble the mounting brackets to the chassis, and then attach the brackets to the rack posts. Two-post accessory kits include the following two-post mounting parts.

- Two Three-hole Mounting Brackets

Each chassis side has attachment pins that align with bracket holes. Pin orientation is symmetric and equidistant, supporting bracket placements where the flange is flush with the front panel, flush with the rear panel, or not flush with either panel. Each bracket hole includes a key opening for placing the bracket flush with the chassis and then locking it into place.



Important: Attachment pins must engage all three upper bracket holes.

Goupilles de fixation doivent être bloquer tous les trois trous de la bride supérieure.

3.2.1 Attaching Mounting Brackets to the Chassis (Two-post)

This section describes the steps to attach mounting brackets to the device chassis.

The following figure displays the front bracket alignment for attaching the device to a two-post rack.

Figure 3-10: Bracket Mount Configuration for Two-post Rack Mount (Example)

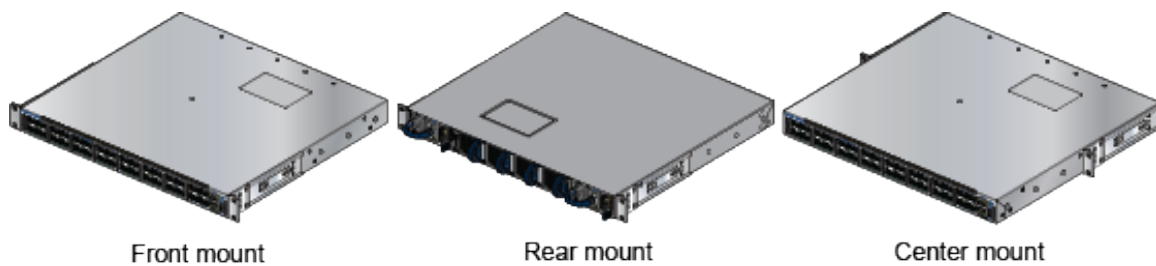
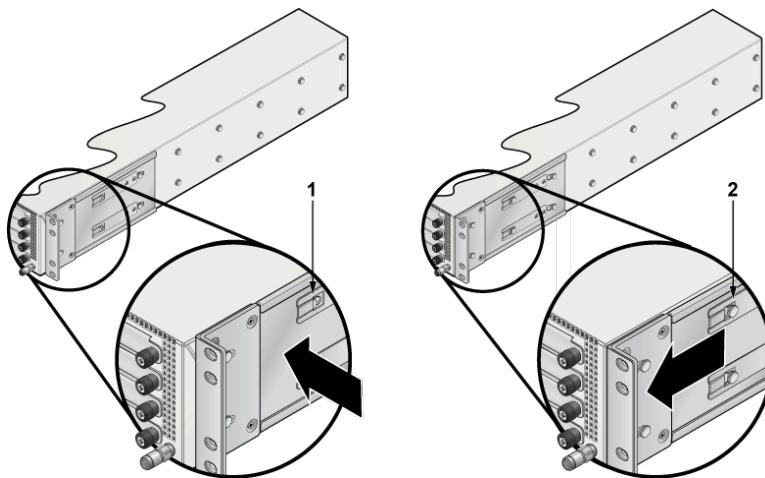

Figure 3-11: Attaching the Mounting Brackets



1 Bracket clip installation

2 Bracket clip removal

The following figure displays improper bracket mounts for two-post rack mounts.

Figure 3-12: Improper Bracket Mount Configuration for Two-post Rack Mount (Example)

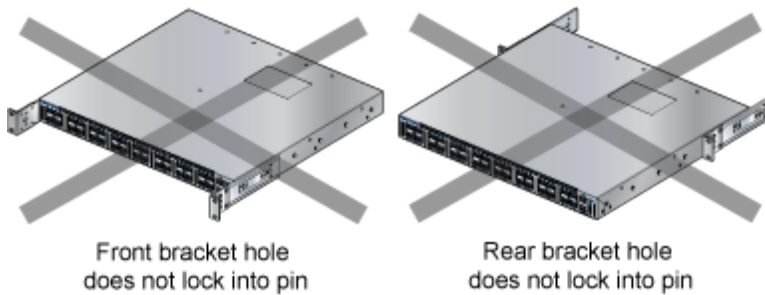

1. Align the mounting brackets with the attachment pins to obtain the desired mounting position.
2. Place the bracket flush on the chassis with attachment pins protruding through key openings.
3. Slide the bracket toward the front flange until the bracket clip locks with an audible click.

The following figure shows the correct bracket attachment for a front mount.

Figure 3-13: Attaching the Mounting Brackets to the Device Chassis

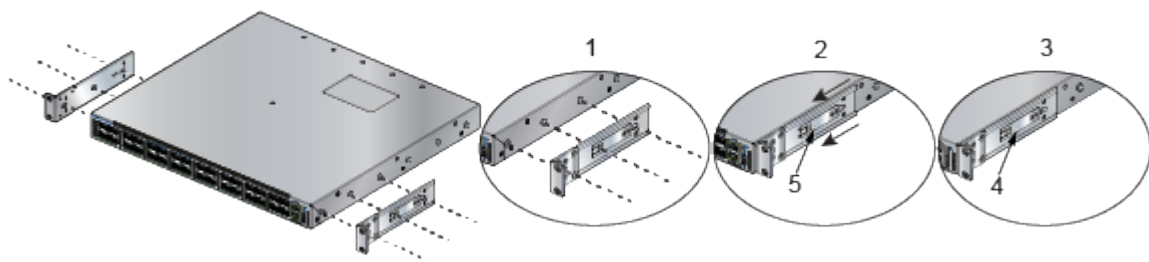

- 1 Align the mounting brackets with the attachment pins to obtain the desired mounting position.
- 2 Place the bracket flush on the chassis with attachment pins protruding through key openings.
- 3 Slide the bracket toward the front flange until the bracket clip locks with an audible click.
- 4 Bracket clip (attached)
- 5 Bracket clip (aligned)

To remove the mounting bracket from the chassis, lift the front edge of the mounting bracket clip with a flat-head screwdriver and slide the bracket away from the front flange (opposite from the installation direction).

3.2.2 Inserting the Device into the Rack

This section describes the steps to insert the device into the rack.

1. Lift the chassis, with the brackets attached, into the rack.
2. Position the flanges against rack posts.
3. Select mounting screws that fit your equipment rack.

4. Attach the bracket flanges to the rack posts.

Figure 3-14: Inserting the Device into the Rack

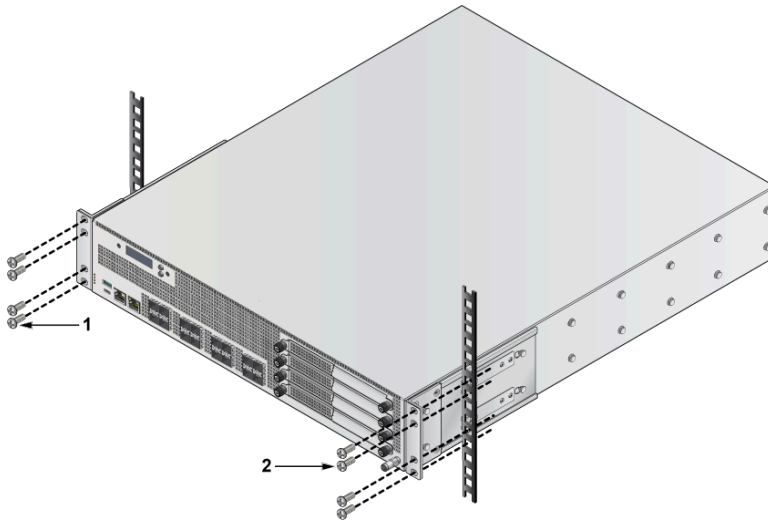

- 1 Attaching chassis securely to rack with the screws (left side)
- 2 Attaching chassis securely to rack with the screws (right side)

Status Indicators

This section describes the meaning of the front-panel LED status indicators.

Table 7: LED Status Indicators

LED Name	LED State	LED Status
System Status LED	Off	No power or amid a power cycle.
	Blinking green	The system is powering up.
	Green	The system is operating in a normal initialization sequence. Normal operations.
	Blue	The locator function is active.
	Amber	The system is malfunctioning. System is overheated, or temperature sensors have recorded passing the software-defined critical threshold. The device will automatically execute a reboot/power cycle.
Cloud Connect Status LED	Off	The system is not connected to CloudVision.
	Green	The system is connected to CloudVision.
	Amber	Problem connecting to CloudVision.
Fan Status LED	Green	All fan modules are operating normally.
	Amber	Single fan module is malfunctioning.
Power Supply Status LED	Off	Power supply unit is not available.
	Green	Power supply unit is fully functional.
	Amber	Power supply unit has a fault.

Cable the Device

The following topics are covered in this section:

- [Grounding the Device](#)
- [Connecting Power Cables](#)
- [Connecting Serial and Management Cables](#)

5.1 Grounding the Device

This section provides instructions for grounding the device.

 **Note:** Grounding cable and grounding lugs are not included with the product.

 **Note:** The cable size should meet local and national installation requirements.

Figure 5-1: Functional Grounding Pad Sockets ZTX-7250S-16S-F Rear Panel

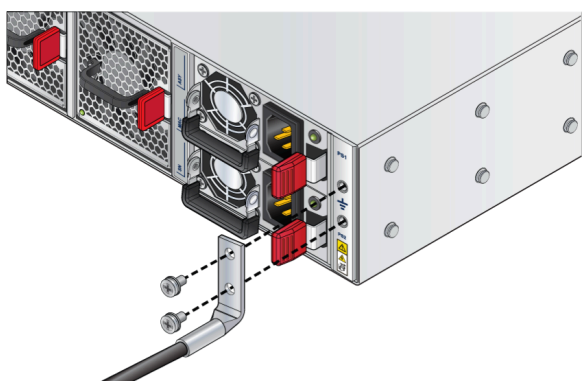
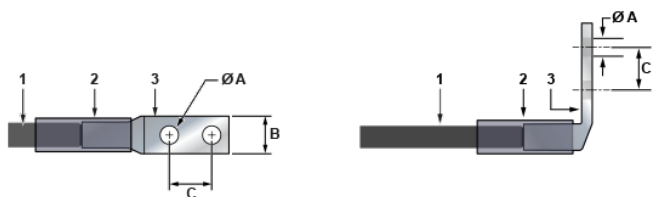



Figure 5-2: Lug Preparation



- | | | | |
|---|--------------------|---|------|
| 1 | Insulated cable | A | 1/4" |
| 2 | Heat-shrink tubing | B | 1/2" |
| 3 | Lug | C | 5/8" |

 **Note:** Dimension B is the width of the lug (not visible on the right-angle lug).

 **CAUTION:** Remove the earth connection if all supply connections are disconnected.

1. Ensure the rack is properly grounded and in compliance with *ETSI EN 300 253*.
2. Ensure a good electrical connection to the rack's grounding point (no paint or isolating surface treatment).
3. Attach the solder terminal lug to an 18 AWG minimum grounding cable and connect it to the grounding point on the device's rear panel.
4. Tighten the screw to secure the lug to the grounding point.
5. Connect the other end of the cable to the nearby grounded surface.

5.2 Connecting Power Cables

Power cords are optional and must be ordered separately. You must use an approved power cord that is compliant with local and national electrical codes or order one from Arista for use with this device.



Important: Installation of this equipment must comply with local and national electrical codes. Consult with the appropriate regulatory agencies and inspection authorities to ensure compliance.

Installation de cet équipement doit être conforme aux codes électriques locaux et nationaux. Si nécessaire, consulter les organismes de réglementation appropriés et des autorités de contrôle pour assurer la conformité.

The device accommodates two power supplies. At least one power supply must connect to a power source. Connecting both power supplies provides redundancy protection. The [Rear Panel](#) displays the location of the power supply unit.

- **Non-redundant configuration:** Connect power to either of the two power supplies.
- **Redundant power supply configuration:** Connect power to both power supplies.
- **Turn off the device:** Remove all power cords and wires from the power supplies.



Important: The installation of this equipment must comply with local and national electrical codes. Consult with the appropriate regulatory agencies and inspection authorities to ensure compliance.

Installation de cet équipement doit être conforme aux codes électriques locaux et nationaux. Si nécessaire, consulter les organismes de réglementation appropriés et des autorités de contrôle pour assurer la conformité.



Important: Read all installation instructions before connecting the system to the power source.

Lire toutes les instructions d'installation avant de brancher le système à la source d'alimentation.



Important: This equipment must be grounded. Never defeat the ground conductor.

Cet équipement doit être mis à la terre. Ne jamais modifier le conducteur de terre.



Important: This unit requires overcurrent protection.

Cet appareil requiert une protection contre les surintensités.

5.2.1 AC Power Supplies

The following AC power supplies are supported:

- PWR-861-AC-RED (ZTX-7250S-16S-F)

The following image displays an AC power supply, including the power socket on the left side of the module. The AC power supply connects to a circuit that provides the required power, as specified in the [Specifications](#) section.

Figure 5-3: AC Power Supply (Example)

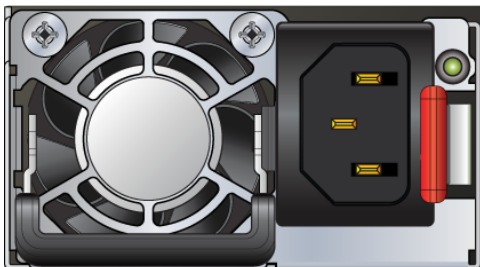

The power supplies require cables that comply with IEC-320 and have a C14 connector. The accessory kit provides two IEC-320 C13 to C14 power cables.

5.3 Connecting Serial and Management Cables

The accessory kit includes the following cables:

- RJ45 to DB9 serial adapter cable
- RJ45 Ethernet cable

The following table lists the pin connections of the RJ45 to DB9 adapter cable.

Table 8: RJ45 to DB9 Connections

RJ45		DB9			RJ45		DB9	
RTS	1	8	CTS		GND	5	5	GND
DTR	2	6	DSR		RXD	6	3	TXD
TXD	3	2	RXD		DSR	7	4	DTR
GND	4	5	GND		CTS	8	7	RTS

Connect the front or rear panel ports as follows:

- **Console (serial) port:** Connect to a computer with the RJ45 to DB9 serial adapter cable. The device uses the following default settings:
 - 9600 baud
 - No flow control
 - 1 stop bit
 - No parity bits
 - 8 data bits
- **Ethernet management port:** Connect to 10/100/1000 management network with RJ45 Ethernet cable.
- **USB port:** The two USB ports (Type-A and Type-C) may be used for software or configuration updates.



CAUTION: Excessive bending can damage interface cables.

Flexion excessive peut endommager les câbles d'interface.

Configuring the Device

Arista devices ship from the factory in Zero Touch Provisioning (ZTP) mode. ZTP configures the device without user intervention by downloading a startup configuration file or a boot script from a location specified by a DHCP server.

To manually configure an Arista device, bypass ZTP. The initial configuration provides one username (admin) that is accessible only through the console port because it does not have a password.

When bypassing ZTP, access the device by logging in as admin, with no password, through the console port. Then, you can configure a password for admin and other password-protected usernames.

The manual configuration procedure described below cancels ZTP mode, logs into the device, assigns a password to the admin, assigns an IP address to the management port, and defines a default route to a network gateway.

As the device boots without a **startup-config** file, it displays the following through the console:

```
The device is in Zero Touch Provisioning mode and is attempting to
download the startup-config from a remote system. The device will not
be fully functional until either a valid startup-config is downloaded
from a remote system or Zero Touch Provisioning is cancelled. To cancel
Zero Touch Provisioning, login as admin and type 'zerotouch cancel'
at the CLI.
localhost login:
```

1. Connect the device to a power source ([Cable the Device](#)).



Note: Arista fixed devices take approximately 5 to 10 minutes to boot completely.

2. Connect the console port to a computer ([Connecting Serial and Management Cables](#)).
3. Log into the device by typing **admin** at the login prompt.

```
localhost login: admin
```

4. Cancel ZTP mode by typing **zerotouch cancel**



Important: This step initiates the device to reboot.

```
localhost> zerotouch cancel
```

5. After the device reboots, log into the device again by typing **admin** at the login prompt.

```
Arista EOS
localhost login: admin
Last login: Fri Mar 15 13:17:13 on console
```

6. Enter global configuration mode.

```
localhost>enable localhost#config
```

7. Assign a password to the admin username using the `username secret` command. In this example, the assigned password is "**pxq123**".

```
localhost (config) #username admin secret pxq123
```

8. Configure a default route to the network gateway. In this example, the default route is 192.0.2.1.

```
localhost (config) #ip route 0.0.0.0/0 192.0.2.1
```

9. Assign an IP address to an Ethernet management port. In this example, the IP address is 192.0.2.8/24.

```
localhost (config) #interface management 1/1  
localhost (config-if-Ma1/1) #ip address 192.0.2.8/24
```

10. Save the configuration by typing `write memory` or `copy running-config startup-config`.

```
localhost#copy running-config startup-config
```

11. When configuring the management port IP address, select the following command to access the device from a host using the address configured in **Step 9**.

```
ssh admin@192.0.2.8
```

Refer to the *Arista Networks User Manual* for the complete device configuration information.

Parts List

This section lists the accessory kit's default and optional installation parts. Each product comes with an accessory kit containing the necessary parts to install it.

Figure 7-1: Four-post Rack Mount Kit Parts

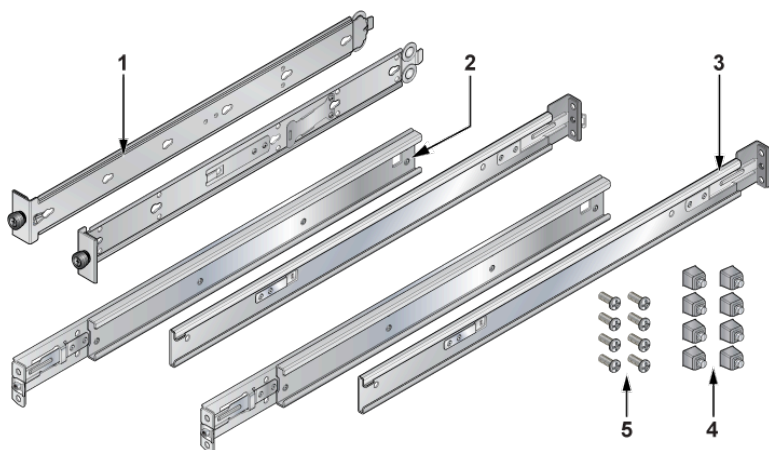

- | | | | |
|---|------------------|---|---|
| 1 | Mounting bracket | 4 | Rack plugs |
| 2 | Rail slide | 5 | Screws (for fixing rack plugs to rail rod and rail slide) |
| 3 | Rail rod | | |

- Cables
 - RJ45 Ethernet cable
 - Console cable
- Power cable (country-specific, only included if specified before purchase)

Product Description

Networking Device	Product Description
ZTX-7250S-16S-F	Arista 7250 ZTX MSS Appliance, up to 100Gbps, 8x 10G SFP+ ports, 8x 10G SFP+ enhanced ports, 4 expansion slots, front to rear air, 2x AC.

Front Panel

This section describes the front panel of the following devices:

- [ZTX-7250S-16S-F](#)

8.1 ZTX-7250S-16S-F

The ZTX-7250S-16S-F MSS Appliance front panel includes the following key components:

Figure 8-1: ZTX-7250S-16S-F Front Panel

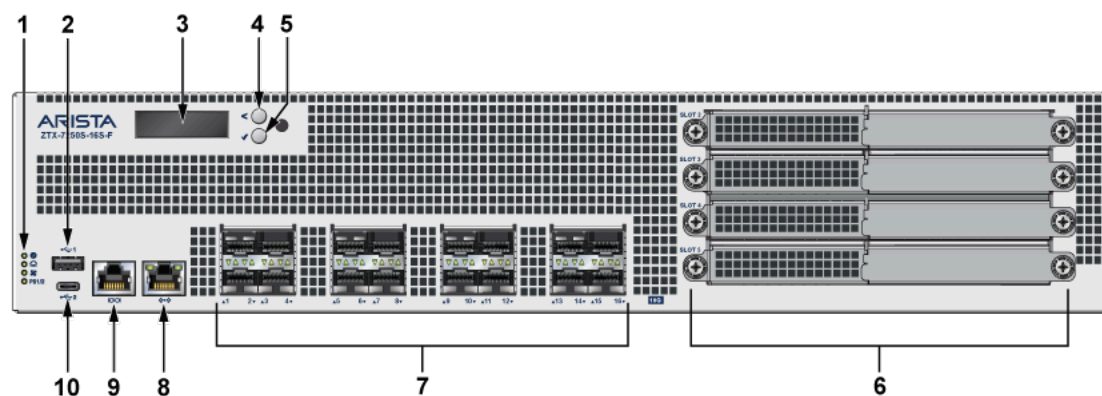

- | | | | |
|---|--------------------|----|---|
| 1 | System status LEDs | 6 | 4x NIM (Network Interface Module) 3.0 slots |
| 2 | USB port Type-A | 7 | 16x 10G SFP+ enhanced ports |
| 3 | LCD panel | 8 | RJ45 Ethernet management port |
| 4 | LCD upper button | 9 | Console port |
| 5 | LCD lower button | 10 | USB port Type-C |

Rear Panel

The section describes the rear panel of the following devices.

- [ZTX-7250S-16S-F](#)

9.1 ZTX-7250S-16S-F

The ZTX-7250S-16S-F MSS Appliance rear panel includes the following key components:

Figure 9-1: ZTX-7250S-16S-F Rear Panel

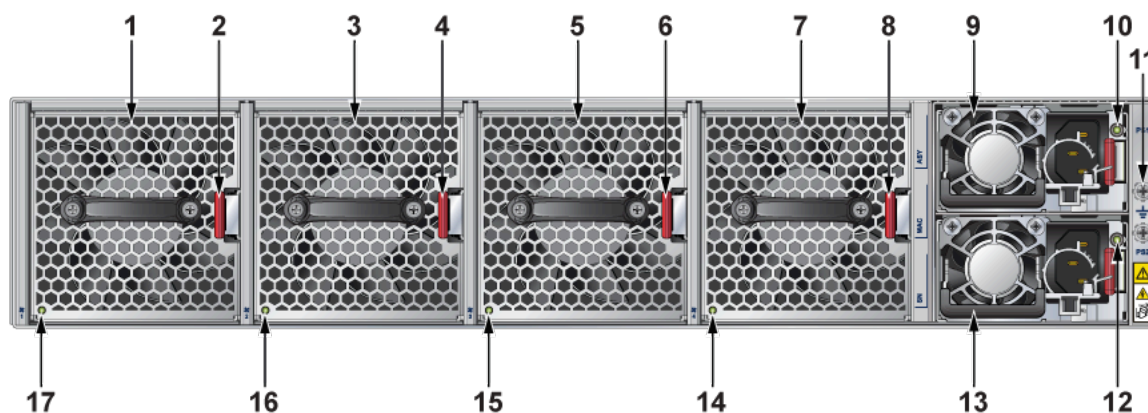

- | | |
|------------------------|-------------------------------|
| 1 Fan module 1 | 10 PS1 LED |
| 2 Fan module latch | 11 Functional grounding point |
| 3 Fan module 2 | 12 PS2 LED |
| 4 Fan module latch | 13 Power supply 2 (PS2) |
| 5 Fan module 3 | 14 Fan status LED |
| 6 Fan module latch | 15 Fan status LED |
| 7 Fan module 4 | 16 Fan status LED |
| 8 Fan module latch | 17 Fan status LED |
| 9 Power supply 1 (PS1) | |

Interface Configuration and Behavior

This section describes the interface configuration and behavior of the following devices:

- [ZTX-7250S-16S-F](#)

10.1 ZTX-7250S-16S-F

This section describes the interface configuration of the ZTX-7250S-16S-F MSS Appliance from a physical layer perspective. This section includes the following topics:

- [Hardware Description](#)
- [Interface Capabilities](#)
- [Speed Configuration](#)
- [Show Commands for Speed and Auto-negotiation Capabilities](#)
- [Supported Transceivers](#)
- [Transceiver Configuration Command Support](#)
- [Front Panel Port LEDs](#)

Hardware Description

Figure 10-1: ZTX-7250S-16S-F Front Panel

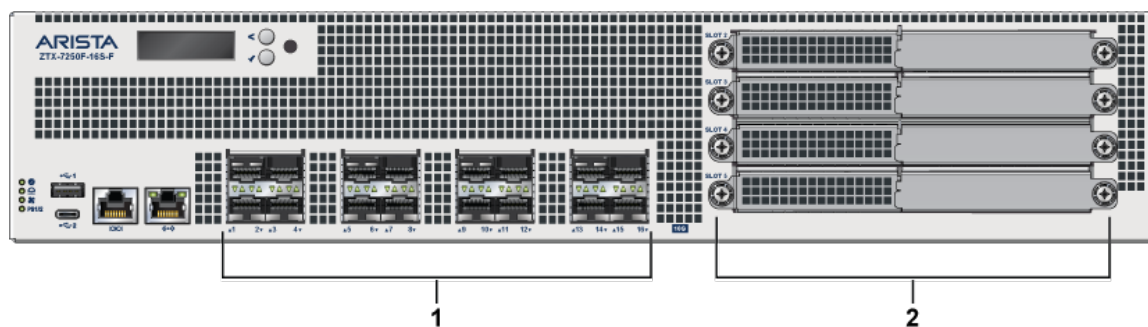

1 16x 10G SFP+ ports

2 4x NIM (Network Interface Module) 3.0 slots

The ZTX-7250S-16S-F MSS Appliance provides 50 Gbps Encrypted / 100 Gbps aggregate throughput and has 16x 10G Ethernet ports (SFP+) and 4x Network Interface Module (NIM) expansion slots. The ports are labeled as 1 through 16.

In the EOS CLI, all the onboard ports have the prefix 1 (Et1/X, X from 1-16) to indicate that they are on the main system rather than the pluggable NIM cards.

Label	Port Number	Port Type	EOS Interface
1	1, 2, 3, 4, 5, 6, 7, 8, 9, 10, 11, 12, 13, 14, 15, 16	SFP+	Et1/1, Et1/2, Et1/3, Et1/4, Et1/5, Et1/6, Et1/7, Et1/8, Et1/9, Et1/10, Et1/11, Et1/12, Et1/13, Et1/14, Et1/15, Et1/16
2	Slot 2, Slot 3, Slot 4, Slot 5	Network Interface Module (NIM)	

Interface Capabilities

This section describes interface capabilities. These capabilities are displayed using the following command:

```
show interfaces <INTF> hardware default
```

Interface speed and auto-negotiation depend on the mac/phy capabilities, the front panel connector, and the type of transceiver inserted. The default capabilities of the device are as follows:

Ports	Speed	Auto-negotiation
Port 1-8	1G/10G	1G full 1G full duplex
Port 9-16	1G/10G	1G/10G full duplex 1G full duplex

When a transceiver is inserted, EOS recognizes the transceiver type. To see which types of transceivers are supported, refer to the [Supported Transceivers](#). If the transceiver is supported, EOS decides the capable speed and auto-negotiation satisfied by both the hardware and the modules. To view the show commands and examples output, refer to [Show Commands for Speed and Auto-negotiation Capabilities](#).

When there is no speed configuration on the interface, EOS applies the default speed. On an RJ45 port, the default configuration is auto-negotiation, enabled with 10G. On an SFP port, the default configuration is auto-negotiation, disabled with 10G.

Speed Configuration

Refer to [#unique_34/unique_34_Connect_42_table_fbn_slp_fzb](#).

Show Commands for Speed and Auto-negotiation Capabilities

Supported speed and auto-negotiation are displayed by the following command when the transceiver is inserted:

```
show interfaces <INTF> hardware
```

```
Arista(config)#show int ET1/1 hardware Ethernet1/1
Model: ZTX-7250F-16S-F
Type: 10GBASE-SR
Speed/duplex: 10G/full(default)
Flowcontrol: rx-(off),tx-(off)
Error correction: unsupported
```

Supported Transceivers

The onboard SFP ports support a wide range of 1G and 10G pluggable transceivers. The first eight ports (ports 1-8) support the following transceivers:

- CAB-SFP-SFP (10GBASE-CR)
- AOC-S-S-10G (10GBASE-AOC)
- SFP-10G-SRL
- SFP-10G-SR
- SFP-10G-LRL
- SFP-10G-LR
- SFP-1G-SX
- SFP-1G-LX
- SFP-1G-T

The last eight ports (ports 9-16) support the following transceivers:

- CAB-SFP-SFP (10GBASE-CR)
- AOC-S-S-10G (10GBASE-AOC)
- SFP-10G-SRL
- SFP-10G-SR
- SFP-10G-LRL
- SFP-10G-LR
- SFP-10G-ER
- SFP-10G-ZR
- SFP-10G-DZ (10GBASE-DWDM)
- SFP-10G-T
- SFP-1G-SX
- SFP-1G-LX
- SFP-1G-T

For details about the different transceivers, modules, and cables, visit <https://www.arista.com/en/products/transceivers-cables>.

Transceiver Configuration Command Support

The first eight ports (ports 1-8) are subject to minor differences in transceiver configuration.

The `shut` and `no shut` configuration commands may not use the SFP transceiver's TX Disable control register software. Instead, the TX Disable hardware low-speed pin signal will always be used. This does not result in operational or behavioral differences for Arista Networks transceivers.

The configuration commands `transceiver frequency` and `transceiver channel` are not supported on the first eight ports (ports 1-8).

Front Panel Port LEDs

When using the `locator-led interface` CLI command, the first eight port LEDs (ports 1-8) may flash at a different rate than the last eight port LEDs (ports 9-16).

Caveats

Auto-negotiation parallel detection on ports 1-8.

Parallel detection is used on the ports 1-8, where the ports can perform auto-negotiation. This happens when the link partner might not support auto-negotiation, or the auto-negotiation is disabled on the device. In this

condition, the port capable of auto-negotiation can determine if it should use auto-negotiation and can match the speed with the other device.

Parallel detection is enabled by default and cannot be disabled. Links can come up with a mismatch in auto-negotiation configuration. If auto-negotiation is enabled on Arista ZTX-7250F-16S-F ports 1-8, but not on the link partner and links can be established, then auto-negotiation status is successful.

```
Arista(config-if-Et1/1)#show int st
Port      Name      Status      Vlan      Duplex Speed  Type      Flags Encapsulation
Et1/1                               connected  routed    a-full a-1G    1000BASE-SX
```

```
LinkPartner(config)#show int ET25 st
Port      Name      Status      Vlan      Duplex Speed  Type      Flags Encapsulation
Et25                               connected  1         full    1G      1000BASE-SX
```

```
Arista(config-if-Et1/1)#show int ET1/1 negotiation detail Ethernet1/1
Auto-Negotiation Mode      1000BASE-X (IEEE Clause 37)
Auto-Negotiation Status    Success
Speed Downshifting         Not Applicable

  Advertisements      Speed      Duplex      Pause
  -----
    Local              1G         full         Disabled
    Link Partner      1G         full         Disabled

  Resolution          1Gb/s     full         Rx=Unsupp.,Tx=Unsupp.
```

LCD Operation

This section describes the operation of the LCD panel.

Figure 11-1: LCD Components

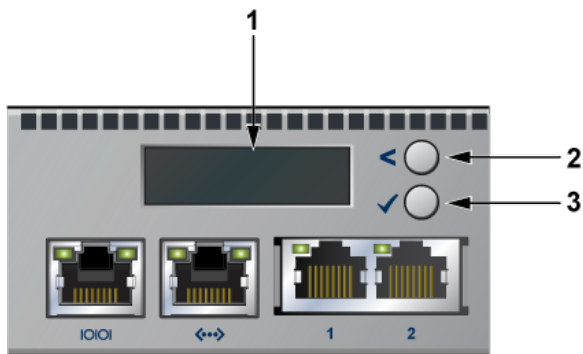

- 1 2x 16 LCD screen
- 2 Top button
- 3 Bottom button

Buttons Functionality

The physical buttons are referenced as follows:

- Top - the top button located above next to the less-than (<) symbol
- Bottom - the bottom button located above next to the check mark (##) symbol

Each button has a functionality based on the button and how long the button is pressed.

Button	Press Duration < 2 Secs	Press Duration >= 2 Secs
Top button	scroll	home
Bottom button	select	confirm

Booting

After the power is on, the LCD displays the image shown below:

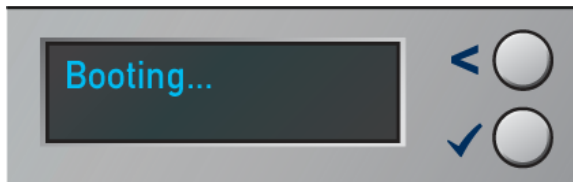

After the bootloader is booted and when the EOS image has begun loading, the LCD displays the image shown below:

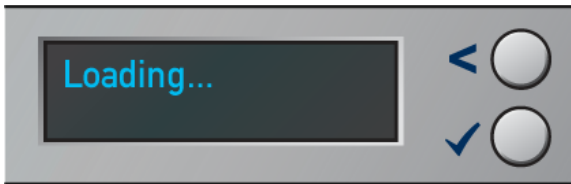

Home Screen

After the EOS has successfully booted, the LCD displays the home screen. The below image is an example output:

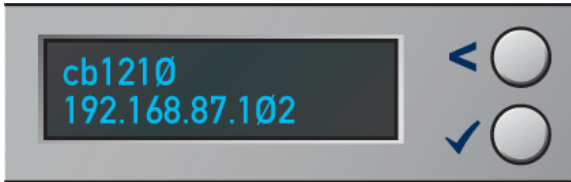

The first line displays the hostname, and the second line displays the IPv4 address of the management interface.

 **Note:** To return to the home screen, you can hold the top button for two seconds (“home” function) at any point.

Menu Choices

At the home screen, select the top button (“scroll” function) to scroll through possible menu choices. The menu choice will be displayed on the top line, and the bottom line will be blank.

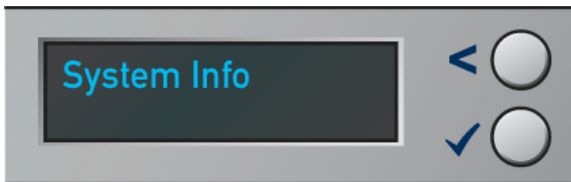

Select the bottom button to select the menu item (**select** function).

 **Note:** If you do not select within 10 seconds, the LCD will return to the home screen. Alternatively, use the “home” function to return to the home screen.

Menu Item Output

Although the physical display is limited to two rows and 16 characters per row, a menu item may display a larger virtual information display. If the width of the line being displayed is wider than the physical screen, then the display will automatically scroll back and forth to display the entire line.

If the number of lines displayed exceeds the physical height, you can scroll through the output using the LCD buttons. Select the top button (“scroll” function) to see earlier lines, and select the bottom button (“select” function) to see later lines.

System Info

The System Info menu item shows the following information:

- Model name
- EOS version
- Hardware revision

- Serial number
- MAC address of the management interface

Example:

The following figure shows the first two lines of the data:

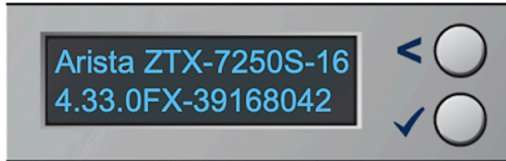

Note: The SKU is longer than the display area and scrolls over the display area.

Regulatory Model Numbers

This section lists the devices' Regulatory Model Number (RMN) described in this document.

Table 9: Regulatory Model Number (RMN)

Networking Device	Regulatory Model Number (RMN)
ZTX-7250S-16S-F	AN1792

RoHS Information

This appendix provides Taiwan BSMI and China RoHS information for the devices described in this guide.

Figure B-1: AN1792

設備名稱：網路設備 · 型號：AN1792						
單元	限用物質及其化學符號					
	鉛 (Pb)	汞 (Hg)	鎘 (Cd)	六價鉻 (Cr(VI))	多溴聯苯 (PBB)	多溴二苯醚 (PBDE)
機構件	—	○	○	○	○	○
印刷電路板	○	○	○	○	○	○
線材	○	○	○	○	○	○
風扇	○	○	○	○	○	○
PSU機構件	○	○	○	○	○	○
PSU印刷電路板	○	○	○	○	○	○
PSU風扇	—	○	○	○	○	○
備考 1."超出0.1wt%"及"超出0.01wt%"係指限用物質之百分比含量超出百分比含量基準值。 2."○"係指該項限用物質之百分比含量未超出百分比含量基準值。 3."—"係指該項限用物質為排除項目。						

AN1792 产品中有害物质的名称及含量

部件名称	有害物質					
	鉛 (Pb)	汞 (Hg)	鎘 (Cd)	六價鉻 (Cr(VI))	多溴聯苯 (PBB)	多溴二苯醚 (PBDE)
机构件	X	○	○	○	○	○
印刷电路板	○	○	○	○	○	○
线材	○	○	○	○	○	○
风扇	○	○	○	○	○	○
PSU机构件	○	○	○	○	○	○
PSU印刷电路板	○	○	○	○	○	○
PSU风扇	X	○	○	○	○	○
本表格依据SJ/T 11364 的规定编制。 ○：表示该有害物质在该部件所有均质材料中的含量均在GB/T 26572规定的限量要求以下。 X：表示该有害物质至少在该部件的某一均质材料中的含量超出GB/T 26572规定的限量要求。 (企业可在此处，根据实际情况对上表中打 "X" 的技术原因进行进一步说明。)						