

# ARISTA

## Quick Start Guide

### 720XP 1RU Cognitive Campus Switches

CCS-720XP-48ZC2  
CCS-720XP-24Y6  
CCS-722XPM-48Y4

CCS-720XP-24ZY4  
CCS-720XP-48TXH-2C-S

CCS-720XP-48Y6  
CCS-722XPM-48ZY8



<b>Headquarters</b>	<b>Support</b>	<b>Sales</b>
5453 Great America Parkway Santa Clara, CA 95054 USA +1-408-547-5500	+1-408-547-5502 +1-866-476-0000	+1-408-547-5501 +1-866-497-0000
<a href="http://www.arista.com/en/">www.arista.com/en/</a>	<a href="mailto:support@arista.com">support@arista.com</a>	<a href="mailto:sales@arista.com">sales@arista.com</a>

© Copyright 2024 Arista Networks, Inc. All rights reserved. The information contained herein is subject to change without notice. The trademarks, logos, and service marks ("Marks") displayed in this documentation are the property of Arista Networks in the United States and other countries. Use of the Marks is subject to the Arista Networks Terms of Use Policy, available at [www.arista.com/en/terms-of-use](http://www.arista.com/en/terms-of-use). Use of marks belonging to other parties is for informational purposes only.

# Contents

<b>Chapter 1: Overview.....</b>	<b>1</b>
1.1 Scope.....	1
1.2 Receiving and Inspecting the Equipment.....	1
1.3 Installation Process.....	1
1.4 Safety Information.....	2
1.5 Obtaining Technical Assistance.....	2
1.6 Specifications.....	3
<b>Chapter 2: Preparation.....</b>	<b>5</b>
2.1 Site Selection.....	5
2.2 Tools and Parts Required for Installation.....	6
2.3 Electrostatic Discharge (ESD) Precautions.....	7
<b>Chapter 3: Rack Mounting the Switch.....</b>	<b>8</b>
3.1 Two-Post Rack Mount.....	8
<b>Chapter 4: Cabling the Switch.....</b>	<b>10</b>
4.1 Grounding the Switch.....	10
4.2 Connecting Power Cables.....	10
4.3 Connecting Serial and Management Cables.....	15
<b>Chapter 5: Configuring the Switch.....</b>	<b>17</b>
<b>Appendix A: Status Indicators.....</b>	<b>19</b>
A.1 Front Indicators.....	19
A.2 Rear Status Indicators.....	21
<b>Appendix B: Parts List.....</b>	<b>23</b>
B.1 Rack Mount Parts.....	23
B.2 Cables.....	23
<b>Appendix C: Front Panel.....</b>	<b>25</b>
<b>Appendix D: Rear Panel.....</b>	<b>28</b>
<b>Appendix E: Maintenance and Field Replacement.....</b>	<b>29</b>
E.1 Considerations.....	29
E.2 Power Supplies.....	29
E.3 Fan Modules.....	31

<b>Appendix F: Regulatory Model Numbers.....</b>	<b>32</b>
<b>Appendix G: Taiwan RoHS Information.....</b>	<b>33</b>

## Overview

---

The Overview section discusses the following topics:

- [Scope](#)
- [Receiving and Inspecting the Equipment](#)
- [Installation Process](#)
- [Safety Information](#)
- [Obtaining Technical Assistance](#)
- [Specifications](#)

### 1.1 Scope

This guide is for properly trained service personnel and technicians who need to install the following Arista Networks Cognitive Campus Switches:

CCS-720XP-48ZC2      CCS-720XP-24ZY4      CCS-720XP-48Y6      CCS-720XP-24Y6  
CCS-720XP-48TXH-2C-S      CCS-722XPM-48ZY8      CCS-722XPM-48Y4



**Note:**

Only qualified personnel should install, service, or replace this equipment.

Seul le personnel qualifié doit installer, service, ou remplacer cet équipement.

### 1.2 Receiving and Inspecting the Equipment

Upon receiving the switch, inspect the shipping boxes and record any external damage. Retain packing materials if you suspect that part of the shipment is damaged; the carrier may need to inspect them.

If the boxes were not damaged in transit, unpack them carefully. Ensure you do not discard any accessories packaged in the same box as the main unit.

Inspect the packing list and confirm that you received all listed items. Compare the packing list with your purchase order. [Parts List](#) provides a list of components included with the switch.

### 1.3 Installation Process

Tasks required to install and use the switch:

1. Select and prepare the installation site ([Site Selection](#)).
2. Assemble the installation tools listed ([Tools and Parts Required for Installation](#)).

3. Attach the mounting brackets and install the switch in an equipment rack ([Rack Mounting the Switch](#)).
4. Connect the switch to the power source and network devices ([Cabling the Switch](#)).
5. Configure the switch ([Configuring the Switch](#)).



**Note:**

**Class 1 Laser Product:** This product has provisions for installing Class 1 laser transceivers, which provide optical coupling to the communication network. After a Class 1 laser product is installed, the equipment is a Class 1 Laser Product. The customer is responsible for selecting and installing the Class 1 laser transceiver and for ensuring that the Class 1 AEL (Allowable Emission Limit) per EN/IEC 60825, CSA E60825-1, and Code of Federal Regulations 21 CFR 1040 is not exceeded after the laser transceiver have been installed. Do not install laser products whose class rating is greater than 1. Refer to all safety instructions that accompany the transceiver before installation. Only Class 1 laser devices, certified for use in the country of installation by the cognizant agency, are to be utilized in this product.

Produit Laser de classe 1: Ce produit a des dispositions pour installer des émetteurs-récepteurs de laser de classe 1 qui offre de couplage au réseau de communication optique. Une fois un produit laser de classe 1 est installé, l'équipement est un produit Laser de classe 1 (Appareil à Laser de Classe 1). Le client est responsable pour sélectionner et installer l'émetteur/récepteur de laser de classe 1 et pour assurer que la classe 1 AEL (limite d'émission admissible) par EN/IEC 6-825, CSA E60825-1, et Code des règlements fédéraux 21 CFR 1040 ne soit pas dépassée après avoir installé l'émetteur/récepteur de laser. Ne pas installer des appareils à laser dont la cote de classe est supérieure à 1. Voir toutes les consignes de sécurité qui ont accompagné l'émetteur-récepteur avant l'installation. Seuls appareils laser de classe 1 certifiés pour une utilisation dans le pays d'installation par l'organisme compétent doivent être utilisées dans ce produit.



**Note:**

This product's ultimate disposal should follow all national laws and regulations.

L'élimination finale de ce produit doit respecter toutes les lois et réglementations nationales.

## 1.4 Safety Information

Refer to the Arista Networks document *Safety Information and Translated Safety Warnings* at <https://www.arista.com/en/support/product-documentation>.

## 1.5 Obtaining Technical Assistance

Any customer, partner, reseller, or distributor holding a valid Arista Service Contract can obtain technical support in any of the following ways:

- **Email:** support@arista.com. This is the easiest way to create a new service request.

Include a detailed description of the problem and the “show tech-support” output.

- **Web:** <https://www.arista.com/en/support>.

You can create a support case through the support portal on our website. You may also download the most current software and documentation and view FAQs, Knowledge Base articles, Security Advisories, and Field Notices.

- **Phone:** +1 866-476-0000 or +1 408-547-5502.



**Note:**

There are no user-serviceable parts inside. Refer all servicing to qualified service personnel.

Aucune pièce réparable par l'utilisateur à l'intérieur. Confiez toute réparation à un technicien qualifié.

## 1.6 Specifications

**Table 1: Switch Specifications (Dimensions and Weights)**

Switch	Size (W x H x D)	Weight
CCS-720XP-48ZC2	48.3 x 4.4 x 31.7 cm (19 x 1.75 x 12.5 inches)	7.0 kg (15.6 lbs.)
CCS-720XP-24ZY4	48.3 x 4.4 x 31.7 cm (19 x 1.75 x 12.5 inches)	6.2 kg (13.6 lbs.)
CCS-720XP-48Y6	48.3 x 4.4 x 31.7 cm (19 x 1.75 x 12.5 inches)	6.9 kg (15.3 lbs.)
CCS-720XP-24Y6	48.3 x 4.4 x 31.7 cm (19 x 1.75 x 12.5 inches)	6.0 kg (13.3 lbs.)
CCS-720XP-48TXH-2C-S	44.0 x 4.4 x 37.5 cm (17.3 x 1.73 x 14.76 inches)	6.0 kg (13.3 lbs)
CCS-722XPM-48ZY8	44.5 x 4.4 x 42.0 cm (17.5 x 1.75 x 16.8 inches)	7.5 kg (16.5 lbs.)
CCS-722XPM-48Y4	44.5 x 4.4 x 36.4 cm (17.5 x 1.75 x 14.5 inches)	6.8 kg (15.0 lbs.)

**Table 2: Switch Specifications (Operational and Storage)**

Switch	Operating Temperature	Storage Temperature	Operating Altitude	Relative Humidity
All	0° to 40°C (32° to 104°F)	-25° to 70°C (-13° to 158°F)	0 to 3,000 meters (0 to 10,000 feet)	5 to 90% (non-condensing)

**Table 3: Switch Power Supply Specifications (Power Input - AC)**

Power Source	PSU Models	Ratings
Input (AC Power)	PWR-1021-AC	100 - 240 VAC, 12 to 5.0 A, 50/60 Hz
Input (AC Power)	PWR-621-AC	100 - 240 VAC, 8.0 to 3.5 A, 50/60 Hz

**Table 4: Switch Power Supply (Power Input - DC)**

Power Source	PSU Models	Ratings	Over-current Protection (Branch Circuit)
Input (DC Power)	PWR-721-DC-RED	-48 to -60 VDC, 25 A	30 A

**Note:**

The following table lists the default PSU compatibility for all switches described in this guide. Some switches could use power supplies that may no longer be available or other PSUs besides the default shown. Contact your local Arista representative for more information.

For switches that support both forward and reverse airflows, add -RED or -BLUE to the PSU model for the airflow desired.

**Table 5: Switch Specifications (Power Draw)**

Switch	Power Draw (Typical / Maximum)	Supported Power Supply	PoE Power Budget Single / Dual PSU
CCS-720XP-48ZC2	141 W / 156 W	PWR-1021-AC-RED	909 W / 1787 W
CCS-720XP-24ZY4	141 W / 156 W	PWR-621-AC-RED	509 W / 1787 W
CCS-720XP-48Y6	68 W / 93 W	PWR-1021-AC	982 W / 1850 W
CCS-720XP-24Y6	67 W / 90 W	PWR-621-AC	583 W / 1853 W
CCS-720XP-48TXH-2C-S	168 W / 199 W	PWR-1021-AC	882 W / 1775 W
CCS-722XPM-48ZY8	134 W / 160 W	PWR-1021-AC-RED	890 W / 1835 W
CCS-722XPM-48Y4	83 W / 102 W	PWR-1021-AC-RED	948 W / 1893 W

<sup>1</sup> Excluding PoE Power.



## Preparation

---

The Preparation section discusses the following topics:

- [Site Selection](#)
- [Tools and Parts Required for Installation](#)
- [Electrostatic Discharge \(ESD\) Precautions](#)

### 2.1 Site Selection

Consider the following criteria when selecting a site to install the switch:

- **Temperature and Ventilation:** For proper ventilation, install the switch where there is ample airflow to the front and back of the switch. The ambient temperature should not go below 0° or exceed 40°C.



**Note:** To prevent the switch from overheating, do not operate it in an area where the ambient temperature exceeds 40°C (104°F).

Pour empêcher l'interrupteur de surchauffer, ne pas utiliser il dans une zone où la température ambiante est supérieure à 40°C (104°F).

- **Airflow Orientation:** The fans and PSUs determine the direction of airflow through the switch. The color of the visible handles or labels indicates the airflow direction.



**Note:** The figures shown use representative Arista switches to illustrate airflow directions. Refer to the rear panel to determine the airflow for your switch.

- **Blue Handle:** Air Inlet module. The following figure shows the airflow through the switch with air inlet modules:

**Figure 2-1: Air Inlet Module**

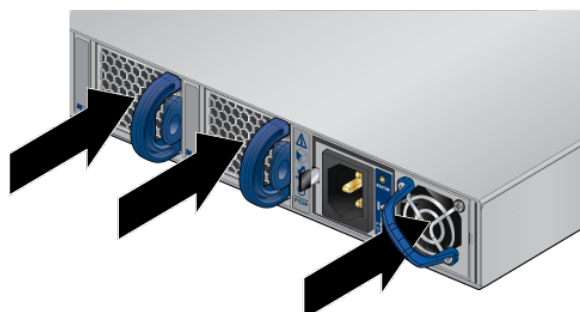

- **Red Handle:** Air Exit module. The following figure shows the airflow through the switch with air exit modules:

**Figure 2-2: Air Exit Module**

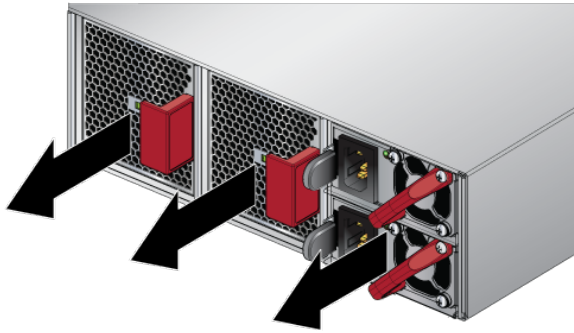

Orient the switch so that the airflow through the switch is from the cooler to the hotter aisle. Contact your sales representative if the airflow direction is incompatible with the installation site.

- **Rack Space:** Install the switch in a 19" rack or cabinet. The switch height is 1 RU. The accessory kit provides mounting brackets for two-post and four-post racks.

When mounting the switch in a partially filled rack, load the rack from bottom to top, with the heaviest equipment at the bottom. Load the switch at the bottom if it is the only item in the rack.

- **Power Requirements:** Power requirements vary by switch and power supply model. Refer to [Specifications](#) for information regarding your specific system.

Two circuits provide redundancy protection. [Cabling the Switch](#) describes power cable requirements.



**Note:** The power input plug-socket combination must be accessible at all times; it provides the primary method of disconnecting power from the system.

La combinaison de la puissance-prise d'entrée doit être accessible en tout temps ; Il fournit le principal moyen de coupure d'alimentation du système.

- **Other Requirements:** Select a site where liquids or objects cannot fall onto the equipment and foreign objects are not drawn into the ventilation holes. Verify these guidelines are met:
  - Clearance areas to the front and rear panels allow for unrestricted cabling.
  - All front and rear panel indicators can be easily read.
  - Power cords can reach from the power outlet to the connector on the rear panel.



**Note:** All power connections must be removed to de-energize the unit.

Toutes les connexions d'alimentation doivent être enlevées pour hors tension l'appareil.

## 2.2 Tools and Parts Required for Installation

Each switch provides an accessory kit containing the parts required to install the switch. In addition to the accessory kit, the following tools and equipment are required to install the switch:

### Two-Post Rack

- Screws or rack mounting nuts and bolts.
- Screwdriver

**Four-Post Rack (Tool-less)**

No additional equipment is required.

**Four-Post Rack (Conventional)**

- Screws or rack mounting nuts and bolts.
- Screwdriver

The accessory kit does not include screws for attaching the switch to the equipment rack. When installing the switch into an equipment rack with unthreaded post holes, nuts are also required to secure the switch to the rack posts.

## 2.3 Electrostatic Discharge (ESD) Precautions

Observe these guidelines to avoid ESD damage when installing or servicing the switch.

- Assemble or disassemble equipment only in a static-free work area.
- Select a conductive work surface (such as an anti-static mat) to dissipate static charge.
- Wear a conductive wrist strap to dissipate static charge accumulation.
- Minimize handling of assemblies and components.
- Keep replacement parts in their original static-free packaging.
- Remove all plastic, foam, vinyl, paper, and other static-generating materials from the work area.
- Select tools that do not create ESD.

## Rack Mounting the Switch

---

This section provides instructions on how to rack mount the switch.

- [Two-Post Rack Mount](#)



**Note:** The rack mounting procedure is identical for all switches this guide covers. Illustrations in this chapter depict the mounting of a DCS-7010T-48 switch.

Les procédure de montage du bâti est identique pour tous les commutateurs visés par ce guide. Illustrations dans ce chapitre montrent le montage d'un interrupteur de DCS-7010T-48.



**Note:** Illustrations use a representative Arista switch. Your device may be differ in appearance.

### 3.1 Two-Post Rack Mount

This section provides instructions for mounting the switch in a two-post rack.

To mount the switch onto a two-post rack, assemble the mounting brackets to the chassis, then attach the brackets to the rack posts. Two-post accessory kits include the following parts:

- 2x mounting brackets
- 6x M4x5 flat head Phillips screws.

The following image displays the proper bracket placement for the rack mount.

**Figure 3-1: Bracket Mount Placement for Rack Mount**



#### 3.1.1 Attaching Mounting Brackets to the Chassis

This section discusses the steps to attach mounting brackets to the chassis.

The following figure displays the front bracket alignment for mounting the switch into a four-post rack.

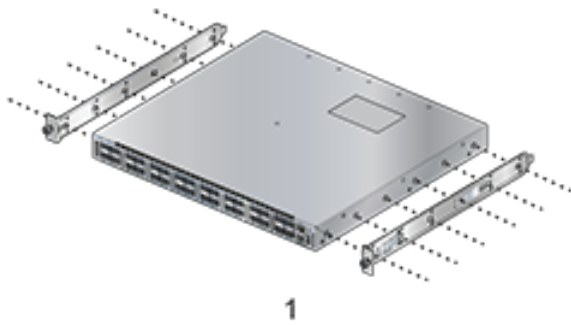
**Figure 3-2: Attaching the Mounting Brackets to the Switch Chassis**

1 Attaching brackets for the front mount

1. Align the mounting brackets with the attachment pins to obtain the desired mounting position.
2. Place the bracket flush on the chassis with attachment pins protruding through key openings.
3. Slide the bracket towards the front flange until the bracket clip locks with an audible click.

To remove the mounting bracket from the chassis, lift the front edge of the mounting bracket clip with a flathead screwdriver and slide the bracket away from the front flange (opposite from the installation direction).

### 3.1.2 Inserting the Switch into the Rack

This section describes the steps to insert the switch into the rack.

1. Lift the chassis, with the brackets attached, into the rack.
2. Position the flanges against rack posts.
3. Select mounting screws that fit your equipment rack.
4. Attach the bracket flanges to the rack posts.

**Figure 3-3: Inserting the Switch into the Rack**

## Cabling the Switch

The Cabling the Switch section discusses the following topics:

- [Grounding the Switch](#)
- [Connecting Power Cables](#)
  - [AC Power Supplies](#)
  - [DC Power Supplies](#)
- [Connecting Serial and Management Cables](#)

### 4.1 Grounding the Switch

After mounting the switch into the rack, connect the switch to the data center ground. [Figure 6: Earth Grounding Pad Sockets](#) display the location of the grounding pads located on the left of the rear panel.



**Note:**

Grounding wires and grounding lugs (M4 x 0.7) are not supplied. Wire size should meet local and national installation requirements. Commercially available 6 AWG wire is recommended for installations in the US.

À la terre et de mise à la terre fils cosses (M4 x 0.7) ne sont pas fournis. Calibre des fils doit satisfaire des exigences de l'installation locale et nationale. Disponible dans le commerce 6 fils AWG est recommandé pour les installations aux États-Unis.

**Figure 4-1: Earth Grounding Pad Sockets**

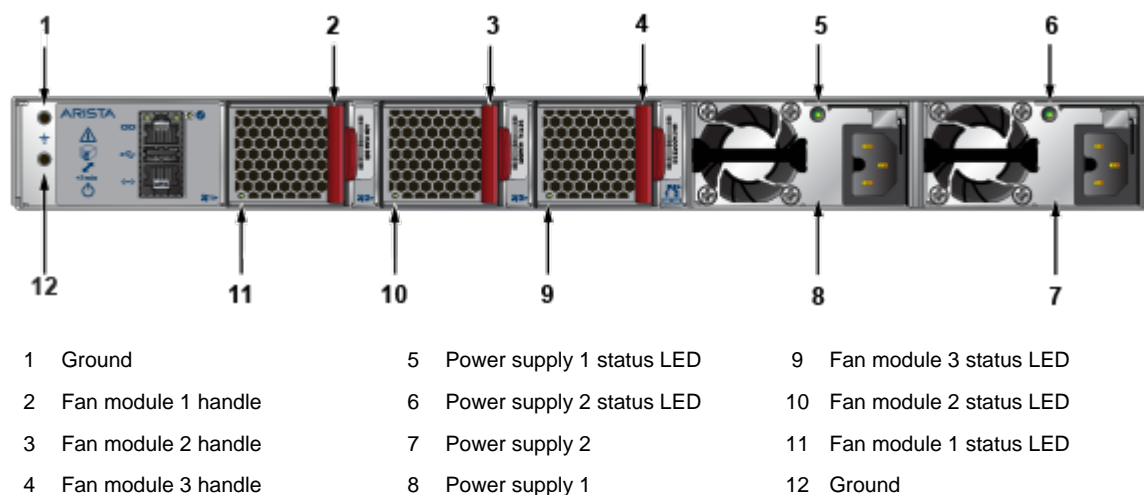

## 4.2 Connecting Power Cables

Power cords are optional and must be ordered separately. You must select an approved power cord that is compliant with local and national electrical codes or order one from Arista for use with the device.



### Warning:

#### (Canada Only) - CCS-722XPM-48ZY8 and CCS-722XPM-48Y4 Signal Equipment High Leakage Current

If used in a Signal Equipment application in Canada, to comply with CSA C22.2 NO. 205:17 leakage current requirements, the following applies:

- For 100-120V operation, connect each AC power supply to its dedicated branch circuit.
- For 200-240V operation, connect each AC power supply to its dedicated branch circuit AND connect the switch to earth (Refer [Figure 6: Earth Grounding Pad Sockets](#)).

#### (Canada uniquement) - Courant de fuite élevé de l'équipement de signalisation CCS-722XPM-48ZY8 et CCS-722XPM-48Y4

Si utilisé dans une application d'équipement de signalisation au Canada, les conditions suivantes doivent être respectées pour se conformer aux exigences en matière de courant de fuite de la norme CSA C22.2 no 205:17:

- Pour un fonctionnement entre 100 et 120 V, raccordez chaque alimentation électrique CA à son propre circuit de dérivation dédié.
- Pour un fonctionnement entre 200 et 240 V, raccordez chaque alimentation électrique CA à son propre circuit de dérivation dédié ET reliez le commutateur à la terre ([Figure 6: Earth Grounding Pad Sockets](#)).



### Note:

Installation of this equipment must comply with local and national electrical codes. Consult with the appropriate regulatory agencies and inspection authorities to assure compliance.

Installation de cet équipement doit être conformes aux codes électriques locaux et nationaux. Si nécessaire, consulter les organismes de réglementation appropriés et des autorités de contrôle pour assurer la conformité.

The switch operates with two installed power supplies. At least one power supply must connect to a power source. Two circuits provide redundancy protection. The [Rear Panel](#) displays the location of the power supplies on the switch's rear panel.



### Note:

Read all installation instructions before connecting the system to the power source.

Lire toutes les instructions d'installation avant de brancher le système à la source d'alimentation.

- **Non-Redundant Configuration:** Connect power to either of the two power supplies.
- **Redundant Power Supply Configuration:** Connect power to both power supplies.
- **Turn off the Switch:** Remove all power cords and wires from the power supplies.



### Note:

This equipment must be grounded. Never defeat the ground conductor.

This unit requires overcurrent protection.

---

Cet équipement doit être mis à la terre. Ne jamais modifier le conducteur de terre.  
Cet appareil requiert une protection contre les surintensités.

## 4.2.1 AC Power Supplies

The following AC power supplies are supported.

- PWR-621-AC-RED
- PWR-621-AC-BLUE
- PWR-1021-AC-RED

[Figure 7: AC Power Supply \(PWR-1021-AC-RED\)](#) displays an AC power supply, including the power connector (C16), on the right side of the module. The AC power supply connects to a circuit that provides the required power, as specified by [Specifications](#).

**Figure 4-2: AC Power Supply (PWR-1021-AC-RED)**

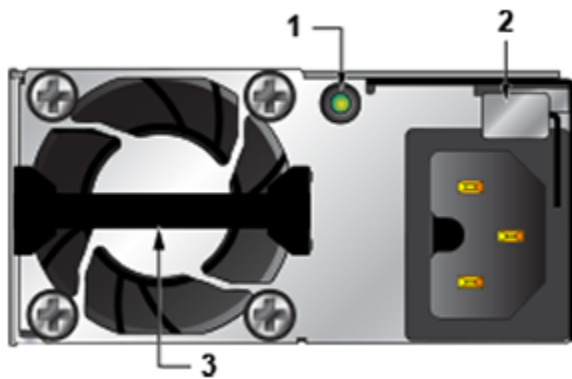

1 Power supply status LED

2 Release

3 Handle

The power supplies have a C16 connector and require cables that comply with IEC-320.

## 4.2.2 DC Power Supplies

The following DC power supplies are supported.

PWR-721-DC-RED

[Figure 8: DC Power Supply \(PWR-721-DC-RED\)](#) displays a DC power supply.



Figure 4-3: DC Power Supply (PWR-721-DC-RED)

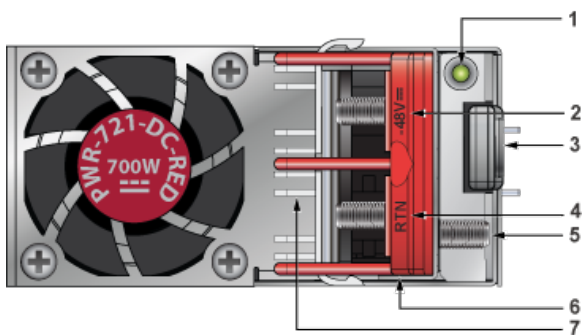

- |                           |                        |                 |
|---------------------------|------------------------|-----------------|
| 1 Power supply status LED | 4 Battery return (RTN) | 7 Plastic cover |
| 2 -48V                    | 5 Protective earth     |                 |
| 3 Release                 | 6 Handle               |                 |

**Note:**

A disconnect device must be provided as part of the installation.

Assure power is removed from DC circuits before performing any installation actions. Locate the disconnect device, circuit breakers, or fuses on DC power lines servicing the circuits. Turn off the power line circuits or remove the fuses.

Wire size must comply with local and national requirements and electrical codes. Use only copper wire.

Apply ground connection to the switch first during installation and remove last when removing power.

Un dispositif de sectionnement doit être fourni dans le cadre de l'installation.

Pouvoir assurer qu'il est retiré de circuits DC avant d'effectuer des actions d'installation . Localiser les disjoncteurs ou des fusibles sur les lignes de courant continu desservant les circuits. Coupez les circuits de lignes d'alimentation ou retirer les fusibles.

Le calibre du fil doit être conforme aux exigences locales et nationales et les codes électriques. Utiliser du fil de cuivre.

Appliquer connexion à la terre à l'interrupteur premier lors de l'installation et de supprimer la dernière alimentation lors du débranchement.

#### 4.2.2.1 Wire and Lug Preparation

Before installing, remove power from DC circuits by turning off the power line servicing the circuits. Prepare the stranded wiring before you begin a DC power installation.



**Note:** Stranded copper wiring is required and should meet local and national installation requirements. Wires and grounding lugs are not supplied.

1. Attach an ESD grounding strap.
2. Prepare the stranded copper wiring for the power supply to be used. [Table 6: Wiring, Lug, and Tightening Torques for DC PSU](#) provide wiring, lug, and tightening torque information for the power supplies covered in this guide.

**Table 6: Wiring, Lug, and Tightening Torques for DC PSU**

PSU	Wire Size(1)		Lug Type(1)	Tightening Torque	
	(AWG)	(mm <sup>2</sup> )		Nm	in lbs.
PWR-721-DC-RED	10 - 12	6.0 - 4.0	Twin #10 studs spaced for dual-hole lug with 5/8" hole spacing.	2.7	24

1. Unless otherwise noted, applies to -48V, battery return, and protective earth wires.

3. Strip the wires to the appropriate length for the lugs to be used.
4. Select agency-approved compression (pressure) lugs for wiring terminations.
5. Slip on heat-shrink tubing on the wire ends before assembling the lugs onto the wire.
6. Crimp the lugs with the proper tool, and assure that the tubing extends over the barrel of the lugs and the insulation on the wires ([Figure 9: Lugs Wiring Terminations](#)).

**Figure 4-4: Lugs Wiring Terminations**

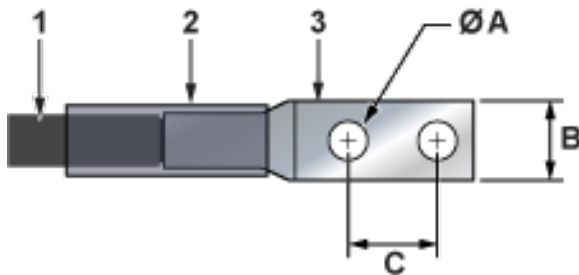

- |                      |                             |        |
|----------------------|-----------------------------|--------|
| 1 Insulated wire     | 3 Lug (all three terminals) | B 1/2" |
| 2 Heat-shrink tubing | A 1/4"                      | C 5/8" |

7. Shrink the tubing with a heat gun.

#### 4.2.2.2 Connecting a DC Power Supply to Power Source

To connect a DC power supply to a power source:

1. Prepare the stranded wiring ([Wire and Lug Preparation](#)).
2. Attach the appropriate lugs to the source DC wires.
3. Connect the DC-input wires to the appropriate terminals using the specified torque ([Table 6: Wiring, Lug, and Tightening Torques for DC PSU](#)) in the following order.



**Note:** Remove terminal covers as needed.

- a. Ground wire to the Protective Earth (PE) terminal.
- b. Negative source DC cable to the negative (- / -48V) terminal.

Positive (+) source DC cable to the positive (+ / Rtn) terminal.



**Note:**

Assure power is removed from DC circuits before performing any installation actions. Locate circuit breakers or fuses on DC power lines servicing the circuits. Turn off the power line circuits or remove the fuses.

Wire size must comply with local and national requirements and electrical codes. Use only copper wire.

Apply the ground connection first during installation and remove it last when removing power.

Assurez-vous de pouvoir retirer des circuits en courant continu avant d'effectuer toute action d'installation. Localiser les disjoncteurs ou fusibles sur les lignes électriques DC entretien des circuits. Mettez hors tension le circuit ligne ou retirer les fusibles.

Calibre doit respecter les exigences locales et nationales et les codes de l'électricité. Utiliser seulement du fil de cuivre.

Appliquer le motif connexion tout d'abord pendant l'installation et supprimer dernière lors du retrait de puissance.

4. Replace the terminal covers as required.

## 4.3 Connecting Serial and Management Cables

The accessory kit includes the following cables:

- RJ-45 to DB-9 serial adapter cable.
- RJ-45 Ethernet cable.

[Table 7: RJ-45 to DB-9 Connections](#) lists the pin connections of the RJ-45 to DB-9 adapter cable.

**Table 7: RJ-45 to DB-9 Connections**

RJ-45		DB-9			RJ-45		DB-9	
RTS	1	8	CTS		GND	5	5	GND
DTR	2	6	DSR		RXD	6	3	TXD
TXD	33	2	RXD		DSR	7	4	DTR
GND	4	5	GND		CTS	8	7	RTS



**Note:** RJ-45 to DB-9 connections: For the console management port on the rear panel, RJ-45 pin 1 (RTS) is connected to RJ-45 pin 8 (CTS); RJ-45 pin 2 (DTR) and RJ-45 pin 7 (DSR) are not electrically connected to any signal.

[Figure 10: Rear Panel Management Ports](#) displays management ports on the rear panel of the CCS PoE switches. The [Front Panel](#) and [Rear Panel](#) display all switches' front and rear panels, which this guide covers.

Figure 4-5: Rear Panel Management Ports

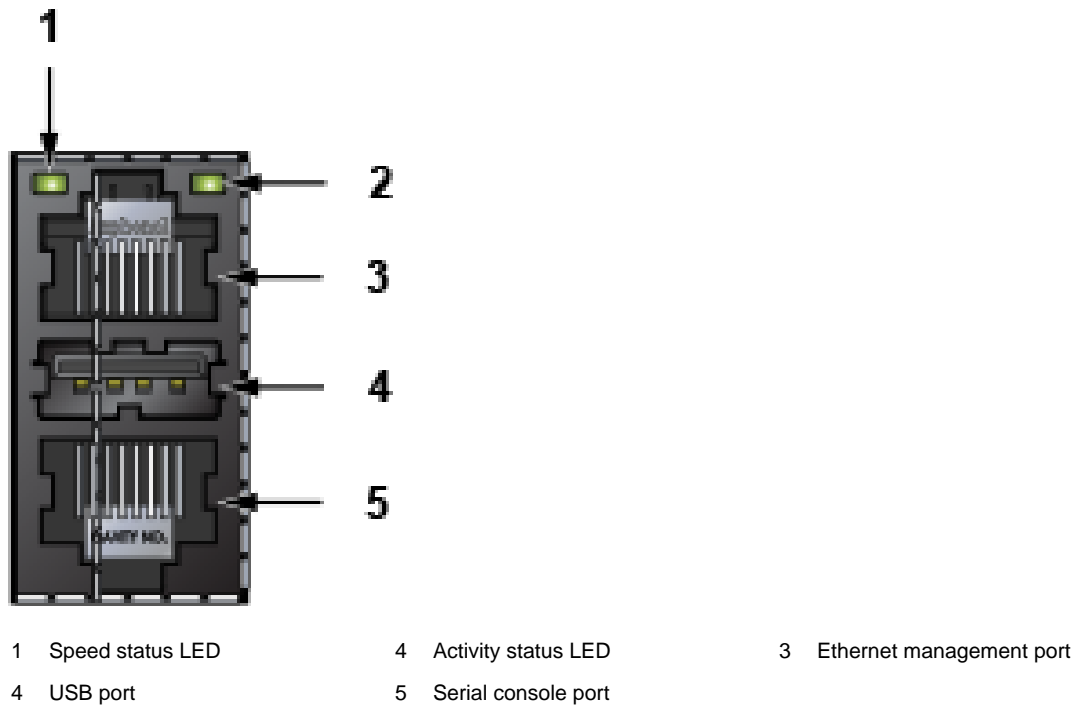

Connect management ports as follows:

- **Console (Serial) Port:** Connect to a PC with the RJ-45 to DB-9 serial adapter cable. The switch uses the following default settings:
  - 9600 baud
  - No flow control
  - 1 stop bit
  - No parity bits
  - 8 data bits
- **Ethernet Management Port:** Connect to 10/100/1000 management network with RJ-45 Ethernet cable.
- **USB Port:** The USB port may be used for software or configuration updates.



**Note:**

Excessive bending can damage interface cables, especially optical cables.

Flexion excessive peut endommager les câbles d'interface, notamment des câbles optiques.

## Configuring the Switch

---

Arista switches ship from the factory in Zero Touch Provisioning (ZTP) mode. ZTP configures the switch without user intervention by downloading a startup configuration file or a boot script from a location specified by a DHCP server. To manually configure a switch, ZTP is bypassed. The initial configuration provides one username (`admin`) that is accessible only through the console port because it has no password.

When bypassing ZTP, initial switch access requires logging in as `admin`, with no password, through the console port. Then, you can configure an `admin` password and other password-protected usernames.

This manual configuration procedure cancels ZTP mode, logs into the switch, assigns a password to the `admin`, assigns an IP address to the management port, and defines a default route to a network gateway.

1. Provide power to the switch ([Cabling the Switch](#)).
2. Connect the console port to a PC ([Connecting Serial and Management Cables](#)).

As the switch boots without a *startup-config* file, it displays the following through the console:

```
The device is in Zero Touch Provisioning mode
and is attempting to download the startup-config
from a remote system. The device will be fully
functional after a valid startup-config is
downloaded from a remote system or Zero Touch
Provisioning is canceled. To cancel Zero
Touch Provisioning, log in as an admin and
type 'zerotouch cancel' in the CLI.
```

```
localhost login:
```

3. Log into the switch by typing `admin` at the login prompt.

```
localhost login: admin
```

4. Cancel ZTP mode by typing `zerotouch cancel`.



**Important:** This step initiates a switch reboot.

```
localhost> zerotouch cancel
```

5. After the switch boots, log into the switch again by typing `admin` at the login prompt.

```
Arista EOS
localhost login: admin
Last login: Fri Mar 15 13:17:13 on console
```

6. Enter global configuration mode.

```
localhost> enable
localhost# config
```

7. Assign a password to the **admin** username with the **username secret** command.

```
localhost(config)# username admin secret pxq123
```

8. Configure a default route to the network gateway.

```
localhost(config)# ip route 0.0.0.0/0 192.0.2.1
```

9. Assign an IP address (**192.0.2.8/24** in this example) to an Ethernet management port.

```
localhost(config)# interface management 1  
localhost(config-if-Ma1/1)# ip address 192.0.2.8/24
```

10. Save the configuration by typing **write memory** or **copy running-config startup-config**.

```
localhost# copy running-config startup-config
```

11. When the management port IP address is configured, select this command to access the switch from a host using the address configured in Step 9:

```
ssh admin@192.0.2.8
```

Refer to the *Arista Networks User Manual* for complete switch configuration information.

## Status Indicators

---

The Status Indicators section discusses the following topics:

- [Front Indicators](#)
- [Rear Status Indicators](#)

### A.1 Front Indicators

#### A.1.1 Switch Indicators

Locate the front panel LEDs on the right side of the chassis, where the LEDs display the system, fan, and power supply status. The front panel LEDs are labeled in [Figure 11: System Status Indicators](#) for a representative switch.

**Figure A-1: System Status Indicators**

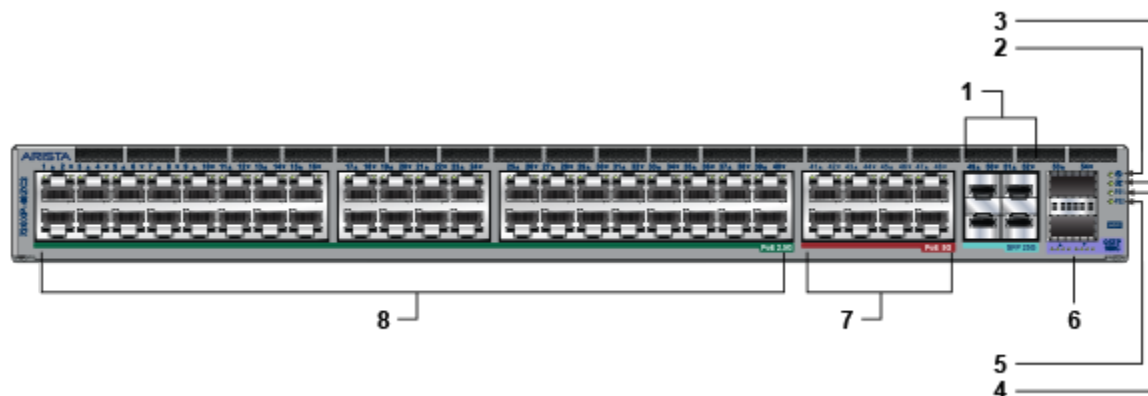

- |   |                           |   |                           |   |                 |
|---|---------------------------|---|---------------------------|---|-----------------|
| 1 | 25G SFP ports             | 2 | System status LED         | 3 | Fan status LED  |
| 4 | Power supply 1 status LED | 5 | Power supply 2 status LED | 6 | 100G QSFP ports |
| 7 | 5G PoE+ ports             | 8 | 2.5G PoE+ ports           |   |                 |

**Table 8: Switch Indicators LED States (Front)**

LED Name	LED State	Device Status
System Status LED	Blinking Green	The system is powering up.
	Green	Normal operations. Due to power supply and fan redundancy, this LED will remain green if a single fan or power supply is missing or in a failed state.
	Blue	The locator function is active.
	Amber	Two or more fans (any combination of fan modules or PSU fans) are disconnected or malfunctioning. The switch will automatically execute a graceful shutdown shortly.
Fan Status LED	Green	All fan and power modules are operating normally.
	Amber	Single fan module is removed or malfunctioning. It is also amber when a PSU is completely removed or has a stuck fan rotor.
	Red	Two or more fans (any combination of fan modules or PSU fans) are disconnected or malfunctioning. The switch will automatically execute a graceful shutdown shortly.
PSU [1:2] Status LED	Green	PSU is functioning and fully operational. AC is present, Aux output is ON, and Main output is ON.
	Off	PSU has been removed or is not operating properly due to the AC cord being unplugged, its fan rotor being stuck, or an internal fault.

## A.1.2 Port Indicators

Port LEDs near their corresponding ports provide the link and operational status. Port LEDs display the Port LED location on the DCS-7050QX-32S switch.

**Figure A-2: Port LEDs**

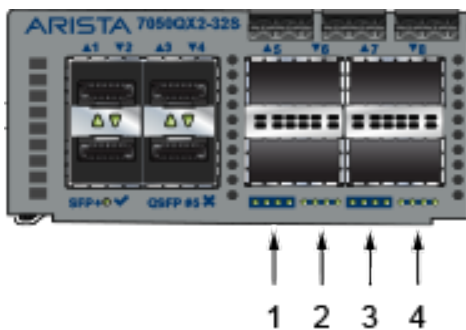

- 1 Port 1 LEDs
- 2 Port 2 LEDs
- 3 Port 3 LEDs
- 4 Port 4 LEDs

Port LED States (Front) provides status conditions corresponding to port LED states. Port LED behavior for QSFP+ and SFP+ ports is consistent.



**Table 9: Port LED States (Front)**

LED State	Status
Off	The port link is down.
Green	The port link is up.
Yellow	The port is software disabled.
Flashing Yellow	The port failed diagnostics.

## A.2 Rear Status Indicators

Access the fan and power supply modules from the rear panel. Each fan and power supply module contains an LED that reports the module status.

Fan Status LEDs are on the fan modules, as displayed in Fan Status LED.

**Figure A-3: Fan Status LED**

1 Fan module status LED

Fan Status LED States (Rear) provide conditions corresponding to fan status LED states.

**Table 10: Fan Status LED States (Rear)**

LED State	Status
Off	The fan module is not detected. If it is inserted, it may not be seated properly.
Green	The fan is operating normally. This LED state is exclusive to its fan module and independent of the states of its neighboring fans and power supplies.
Red	The fan has failed.

The AC Power Supply Status LEDs are on the power supply modules, as displayed in the Representative AC Power Supply Status LED (PWR-1021-AC-RED) .

**Figure A-4: Representative AC Power Supply Status LED (PWR-1021-AC-RED)**

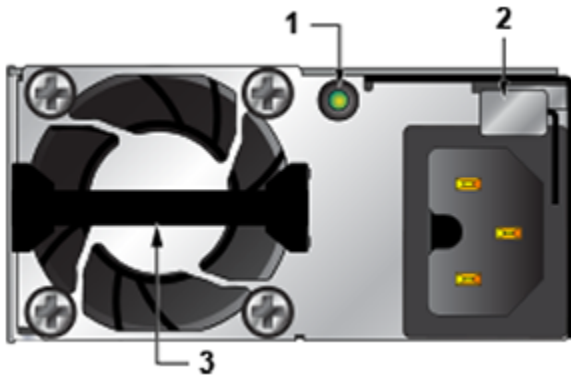

1 Power supply status LED

2 Release

3 Handle

AC Power Supply Status LED States (Rear) provides conditions corresponding to the AC power supply status LED states.

**Table 11: AC Power Supply Status LED States (Rear)**

Power Supply State	PWR-1021-AC-RED
Input power present Normal operation	Green
Input power present Power Supply fault	ON/OFF: ON when PSU output is ON, OFF when PSU Output is OFF
Input power present Power Supply FAN fault	FLASH 800 ms ON / 800 ms OFF
No Input power Supply installed in chassis	OFF
Input power present Supply not installed in chassis	Green



**Note:** You can narrow the error condition by logging in to the switch to view the specific device state. Refer to the *Arista User Manual's Switch Environment Control* chapter under *Viewing Environment Status*, for further information on the `show environment` commands.

## Parts List

---

Each switch provides an accessory kit containing the parts required to install the switch. This section lists the installation parts contained in the switch accessory kit.

The Parts List section discusses the following topics:

- [Rack Mount Parts](#)
- [Cables](#)

### B.1 Rack Mount Parts

This section discusses the rack mounting parts and cables required for the device's installation.

#### B.1.1 Two-Post or Four-Post Rack Mount Parts

This section lists the parts required for a two-post and four-post mounting system.

**Figure B-1: Two-Post or Four-Post Rack Mount Parts**



Quantity	Description
2	Mounting brackets
6	M4 x 5 Flat head Phillips Screws

### B.2 Cables

This section lists the cables required for the device's installation.

Quantity	Description
1	RJ-45 Patch Panel Cable
1	RJ-45 to DB9 Adapter Cable
<b>Optional (must be ordered separately)</b>	
	Power cables: IEC-320/C14-C15, 13 A, 250 V



**Note:**

All provided power cables are for use only with Arista products.

**警告**

すべての電源コードは提供する製品で使用するためだけを目的としている。

**電源コードの他の製品での使用の禁止**

Aristaが提供するすべての電源コードは、Aristaの製品でのみ使用してください。

## Front Panel

This section displays the front panel of all switches covered by this guide.

**Figure C-1: CCS-720XP-48ZC2**

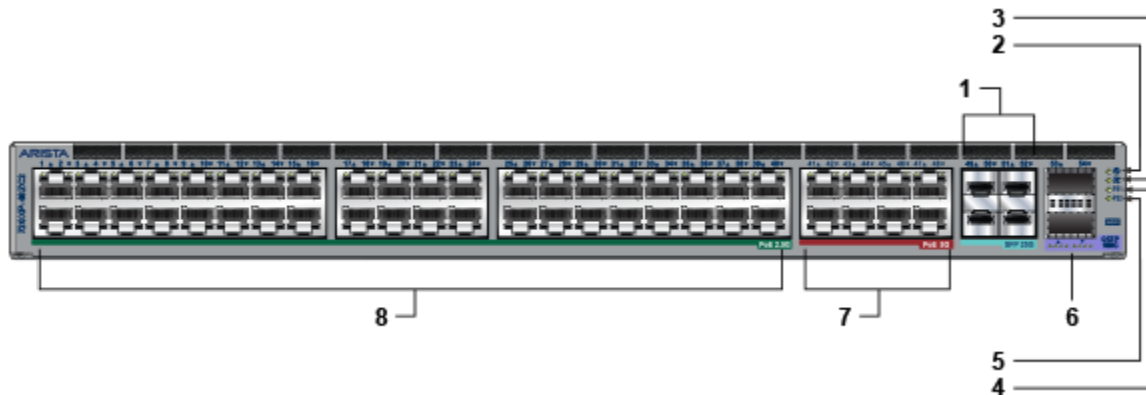

- |                             |                             |                   |
|-----------------------------|-----------------------------|-------------------|
| 1 25G SFP ports             | 2 System status LED         | 3 Fan status LED  |
| 4 Power supply 1 status LED | 5 Power supply 2 status LED | 6 100G QSFP ports |
| 7 5G PoE+ ports             | 8 2.5G PoE+ ports           |                   |



**Note:** The 2.5G ports are PoE+ (30 W max), and the 5G ports are PoE+ (60 W max).

**Figure C-2: CCS-720XP-24ZY4**

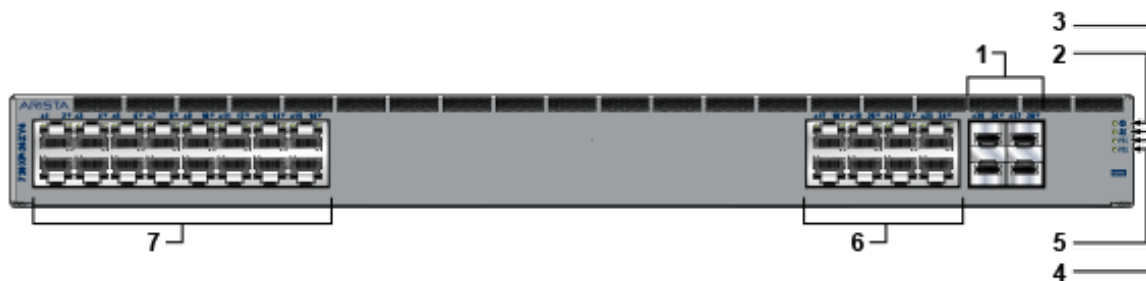

- |                             |                             |                  |
|-----------------------------|-----------------------------|------------------|
| 1 25G SFP ports             | 2 System status LED         | 3 Fan status LED |
| 4 Power supply 1 status LED | 5 Power supply 2 status LED | 6 5G PoE+ ports  |
| 7 2.5G PoE+ ports           |                             |                  |



**Note:** The 2.5G ports are PoE+ (30 W max) and the 5G ports are PoE+ (60 W max).

Figure C-3: CCS-720XP-48Y6

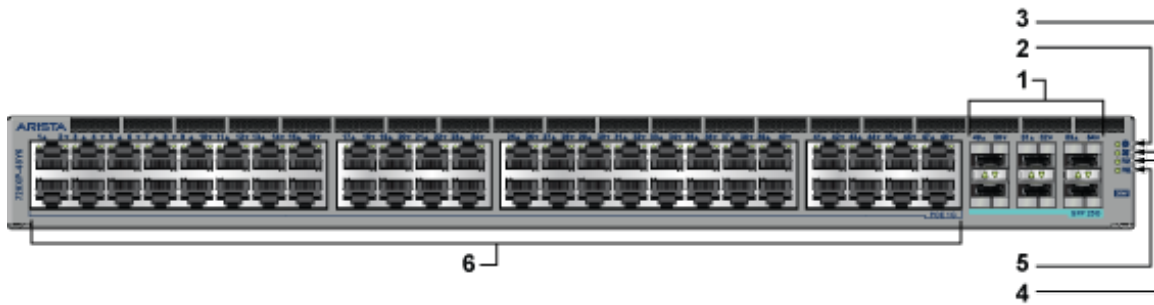

- |                             |                             |                  |
|-----------------------------|-----------------------------|------------------|
| 1 25G SFP ports             | 2 System status LED         | 3 Fan status LED |
| 4 Power supply 1 status LED | 5 Power supply 2 status LED | 6 1G PoE+ ports  |



**Note:** The 1G ports are PoE+ (30 W max).

Figure C-4: CCS-720XP-24Y6



- |                             |                             |                  |
|-----------------------------|-----------------------------|------------------|
| 1 25G SFP ports             | 2 System status LED         | 3 Fan status LED |
| 4 Power supply 1 status LED | 5 Power supply 2 status LED | 6 1G PoE+ port   |
| 7 1G PoE+ ports             |                             |                  |



**Note:** The 1G ports are PoE+ (30 W max).

Figure C-5: CCS-720XP-48TXH-2C-S

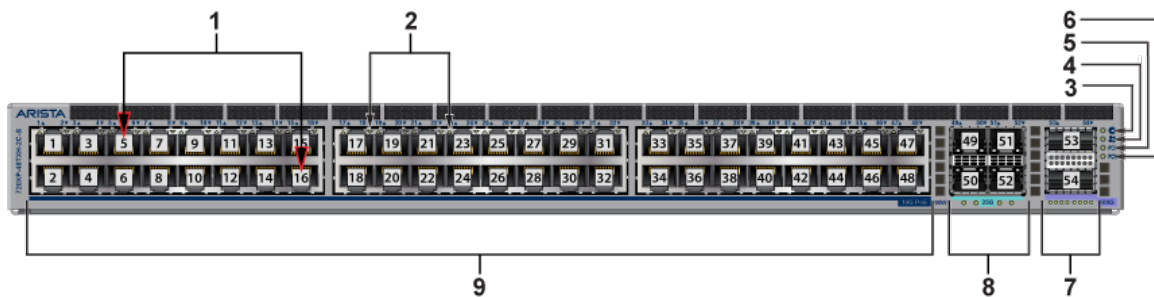

- |                   |                             |                             |
|-------------------|-----------------------------|-----------------------------|
| 1 RJ45 ports      | 2 Connection status LED     | 3 System status LED         |
| 4 Fan status LED  | 5 Power supply 1 status LED | 6 Power supply 2 status LED |
| 7 100G QSFP ports | 8 25G SFP ports             | 9 10G PoE+ ports            |

**Figure C-6: CCS-722XPM-48ZY8**

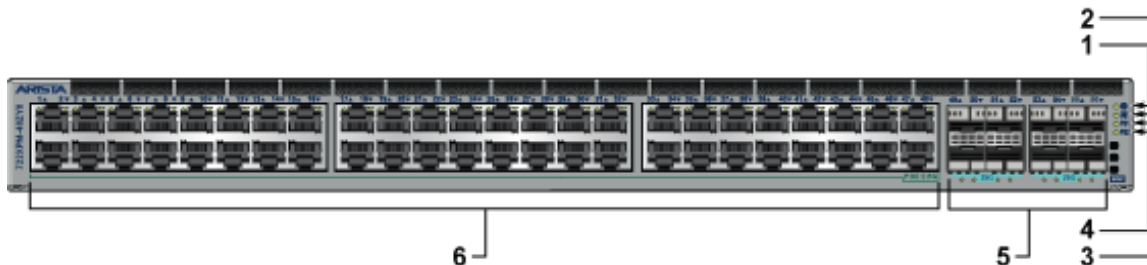

- |                             |                  |                             |
|-----------------------------|------------------|-----------------------------|
| 1 System status LED         | 2 Fan status LED | 3 Power supply 1 status LED |
| 4 Power supply 2 status LED | 5 25G SFP ports  | 6 2.5G PoE+ ports           |



**Note:** The 2.5G ports are PoE+ (60 W max).

**Figure C-7: CCS-722XPM-48Y4**

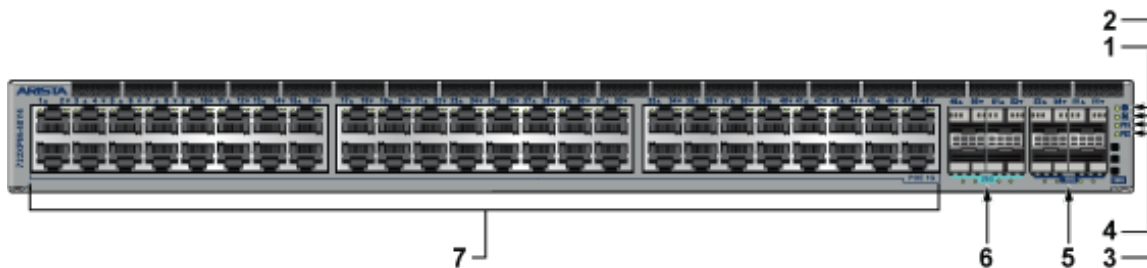

- |                             |                  |                             |
|-----------------------------|------------------|-----------------------------|
| 1 System status LED         | 2 Fan status LED | 3 Power supply 1 status LED |
| 4 Power supply 2 status LED | 5 10G SFP ports  | 6 25G SFP ports             |
| 7 2.5G PoE+ ports           |                  |                             |



**Note:** The 2.5G ports are PoE+ (30 W max).

## Rear Panel

All switches this guide covers use one of the rear panels shown below.



**Note:** Depending on the installed power supply and fan modules, the appearance could differ from those shown.

**Figure D-1: Rear Panel for CCS-720XP-48ZC2 (Representative switch)**

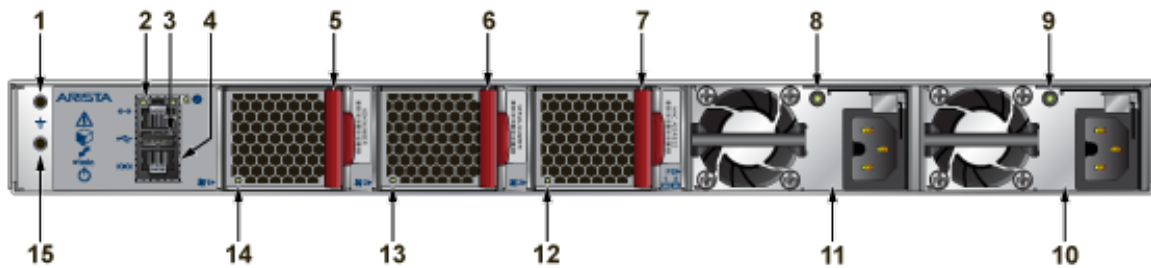

- |                            |                             |                            |
|----------------------------|-----------------------------|----------------------------|
| 1 Ground                   | 6 Fan module 2 handle       | 11 Power supply 1          |
| 2 Ethernet management port | 7 Fan module 3 handle       | 12 Fan module 3 status LED |
| 3 USB port                 | 8 Power supply 1 status LED | 13 Fan module 2 status LED |
| 4 Console serial port      | 9 Power supply 2 status LED | 14 Fan module 1 status LED |
| 5 Fan module 1 handle      | 10 Power supply 2           | 15 Ground                  |



## Maintenance and Field Replacement

---

The Maintenance and Field Replacement section discusses the following topics:

- [Considerations](#)
- [Power Supplies](#)
- [Fan Modules](#)

### E.1 Considerations

Review the following considerations when installing the device.

- All fans and power supplies are hot-swappable.
- The switch can be running while a power supply is being installed or removed, but the power supply being replaced must not be connected to a power source.



**Note:** Saving the switch configuration before replacing a power supply is recommended.

- All slots must be filled or covered with a blank for operation (even though the power supply or fans may not be functional).
- Before you begin, refer to the Arista Networks document Safety Information and Translated Safety Warnings: <https://www.arista.com/en/support/product-documentation>.



**Note:** Refer to your device's ([Front Panel](#)) and ([Rear Panel](#)) panel illustrations to locate the appropriate LED, the release lever or handle, and the handle for the power supply and fan modules.

### E.2 Power Supplies

The following steps are required when removing power supplies from a switch.

#### E.2.1 AC Power Supplies

##### E.2.1.1 Removing an AC Power Supply

1. Ground yourself with an ESD wrist strap.
2. Turn off the power supply to be removed by disconnecting the AC power cable.
3. Push the power supply release lever and remove the power supply.

---

### E.2.1.2 Installing an AC Power Supply

You must make space for installing the power supply by removing an existing one ([Removing an AC Power Supply](#)).

1. Remove the replacement power supply from its packaging.
2. Slide the new power supply into the empty slot.
3. Slide the new power supply into the switch until the power supply is fully seated, and the release lever snaps into place.
4. Connect the power cord to the power supply.
5. Verify the LED(s) on the power supply.



**Note:** The Power Supply status LED is a steady green for normal operation.

6. Verify the new power supply operation by issuing the `show environment power` command.

```
switch# show environment power
```

The command output lists the power supplies in operation and includes the one you replaced.

## E.2.2 DC Power Supplies



**Note:** Select a three-eighth-inch (3/8") hexagon socket wrench for removing the lug nuts.

### E.2.2.1 Removing a DC Power Supply

Before performing any steps, remove power from DC circuits by turning off the power line servicing the circuits.



**Note:** Make sure to remove the ground connection *last* when removing power.

1. Put on a grounded, anti-static ESD strap.
2. Disconnect the power cable from the DC power source.
3. Access the terminal studs by lifting the plastic cover.
4. Remove the flange locking nuts to each of the terminal studs.
5. Disconnect the power cable lug from the terminal studs.
6. Use the power supply release lever to unseat and slide out the power supply.

### E.2.2.2 Installing a DC Power Supply

You must make space for installing the power supply by removing an existing one ([Removing a DC Power Supply](#)) from a power supply slot available on the switch. Perform the following steps to install a DC power supply.

1. Put on a grounded ESD strap.
2. Unbox the new power supply.
3. Insert the new power supply into the empty power supply slot.
4. After you insert the power supply, push gently on the power supply until the power supply is fully seated and locked in place.
5. Connect the DC-input wires to the appropriate terminals using the specified torque ([Table 6: Wiring, Lug, and Tightening Torques for DC PSU](#)) in the following order:

- a. Ground wire to the Protective Earth (PE) terminal.
- b. Negative source DC cable to the negative (- / -48V) terminal.
- c. Positive (+) source DC cable to the positive (+ / Rtn) terminal.

## E.3 Fan Modules

To prevent the switch from overheating, hot-swap fans within 30 seconds. Ensure that the module you are replacing matches those already installed in the switch.

### E.3.1 Removing a Fan Module

The following steps are required when removing or replacing fans from a switch.

1. Ground yourself with an ESD wrist strap.
2. Push the fan module release lever and slide the fan module out of the switch.

### E.3.2 Installing a Fan Module

You must make space for installing the fan module by removing an existing one ([Removing a Fan Module](#)).

1. Remove the replacement fan from its packaging.
2. Slide the new fan module into the switch until the module is fully seated, and the release lever snaps into place.
3. Verify that the fan module is working normally.



**Note:** The fan module status LED should be a steady green for normal operation.

## Regulatory Model Numbers

---

This section lists the Regulatory Model Numbers (RMNs), where applicable, for the product models for the switches described in this document.

**Table 12: Regulatory Model Numbers and Product Numbers**

Regulatory Model Number (RMN)	Product Number(s)
AN1712	CCS-720XP-48ZC2
AN1714	CCS-720XP-24ZY4
AN1713	CCS-720XP-48Y6 CCS-720XP-24Y6
AN1762	CCS-722XPM-48ZY8
AN1763	CCS-722XPM-48Y4
AN1783	CCS-720XP-48TXH-2C-S

## Taiwan RoHS Information

---

This section provides the Taiwan RoHS information for switches this guide covers.

For the Taiwan BSMI RoHS Table, go to <https://www.arista.com/assets/data/pdf/AristaBSMIRoHS.pdf>.