

ARISTA

QUICK START GUIDE

CloudVision AGNI Appliance DCA-AGNI-100

DCA-AGNI-100



[Arista.com](https://www.arista.com)

Arista Networks

DOC-07692-01

Headquarters	Support	Sales
5453 Great America Parkway Santa Clara, CA 95054 USA +1-408-547-5500	+1-408-547-5502 +1-866-476-0000	+1-408-547-5501 +1-866-497-0000
www.arista.com/en/	support@arista.com	sales@arista.com

© Copyright 2025 Arista Networks, Inc. All rights reserved. The information contained herein is subject to change without notice. The trademarks, logos, and service marks ("Marks") displayed in this documentation are the property of Arista Networks in the United States and other countries. Use of the Marks is subject to the Arista Networks Terms of Use Policy, available at www.arista.com/en/terms-of-use. Use of marks belonging to other parties is for informational purposes only.

Contents

- Chapter 1: Overview..... 1**
 - 1.1 Scope..... 1
 - 1.2 Supplemental Documentation..... 1
 - 1.3 Obtaining Technical Assistance..... 1
 - 1.4 Safety Information..... 2
 - 1.5 Specifications..... 2

- Chapter 2: Setup Preparation..... 7**
 - 2.1 Site Selection..... 7
 - 2.2 Receiving and Inspecting the Equipment..... 7
 - 2.3 Electrostatic Discharge (ESD) Precautions..... 8
 - 2.4 Setting up Your System..... 8
 - 2.5 CloudVision AGNI Appliance Setup..... 9
 - 2.5.1 Front Bezel..... 9
 - 2.5.2 Locate the MAC Addresses for the AGNI Appliance..... 10
 - 2.5.3 Rear Panel Ethernet Connections..... 10
 - 2.5.4 DNS Entries..... 11
 - 2.6 CloudVision AGNI Appliance IP Configuration..... 11
 - 2.6.1 Setting up Manual IP Address..... 11

- Chapter 3: CloudVision AGNI Appliance Access..... 18**
 - 3.1 iDRAC..... 18
 - 3.1.1 Web Access into iDRAC (System IPMI)..... 18
 - 3.1.2 Updating the Host Password..... 19
 - 3.1.3 Changing iDRAC Password..... 20

- Chapter 4: Series Status Indicators..... 30**
 - 4.1 LCD Panel Features..... 30
 - 4.2 Status LED Indicators..... 31
 - 4.2.1 iDRAC Direct LED Indicator Codes..... 32
 - 4.2.2 NIC Indicator Codes..... 33
 - 4.2.3 Power Supply Unit Indicator Codes..... 34

- Chapter 5: Rack Installation..... 36**
 - 5.1 Rack Installation..... 36
 - 5.2 Two-Post Rack Mount Parts..... 39

- Chapter 6: Front View of the System..... 40**
 - 6.1 Front View of the System..... 40

- Chapter 7: Rear Panel Features and Indicators..... 42**

Chapter 8: RoHS Declaration Statements..... 43

Overview

This section includes the following topics:

- [Scope](#)
- [Supplemental Documentation](#)
- [Obtaining Technical Assistance](#)
- [Safety Information](#)
- [Specifications](#)

1.1 Scope

This guide is intended for properly trained service personnel and technicians who need to install the Arista CloudVision AGNI Appliance.



Note: Only qualified personnel should install, service, or replace this equipment.

1.2 Supplemental Documentation

Refer to the Arista AGNI User manual or additional configuration requirements at <https://www.arista.com/en/support/product-documentation>.

1.3 Obtaining Technical Assistance

All customers, partners, resellers, or distributors holding a valid Arista Service Contract can obtain technical support in any of the following ways:

- **Email:** <mailto:support@arista.com>.

This is the easiest way to create a new service request. Include a detailed description of the problem and the “show tech-support” output.

- **Web:** <https://www.arista.com/en/support/customer-support>.

You can create a support case through the support portal on our website. You may also download the most current software and documentation and view FAQs, Knowledge Base articles, Security Advisories, and Field Notices.

- **Phone:** +1-866-476-0000 or +1-408-547-5502.

1.4 Safety Information

Refer to the Arista Networks document *Safety Information and Translated Safety Warnings* at: <https://www.arista.com/en/support/product-documentation>.

1.5 Specifications

The following Appliance Specifications table lists the specifications of the Arista DCA-AGNI-100 CloudVision AGNI Appliance.

Figure 1-1: System Dimensions

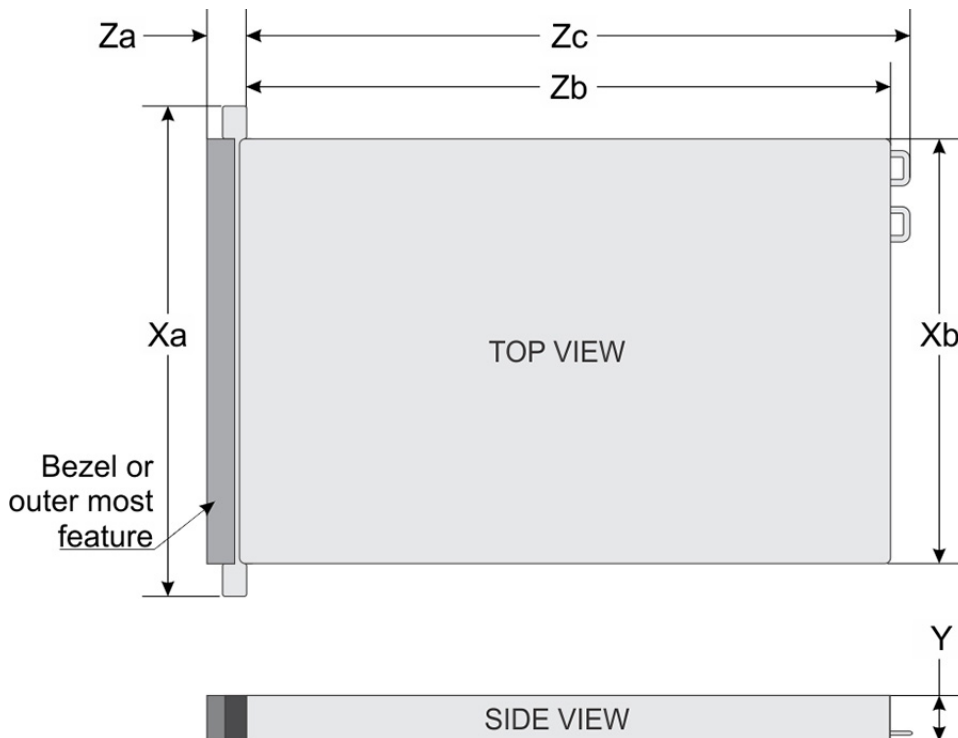

System	Dimensions
Xa	482.0 mm (18.97 inches)
Xb	434.0 mm (17.08 inches)
Y	42.8 mm (1.7 inches)
Za	35.84 mm (1.41 inches) (with bezel) 22 mm (0.87 inches) (without bezel)
Zb	734.95mm (28.92 inches)
Zc	748.79mm (29.47 inches)

Table 1: Weight Specifications

This table below shows the unit weight specifications with all installed drives or SSDs.

Weight	Maximum weight (with all drives/SSDs)
8 x 2.5-inch drive system	16.58 Kg (36.55 lb)

Table 2: Power Specifications

This table below shows the power supply specifications.

Power Draw	Specifications
Power Draw (Typical) 550 W AC	Platinum 50/60 Hz 100 240 V AC, auto-arranging
Power Draw (Typical) 450 W AC	Bronze 50/60 Hz 100 240 V AC, auto-arranging

Table 3: Temperature Specifications

The table below shows the optimal working temperature specifications.

Temperature	Specifications
Storage	-40°C to 65°C (-40°F to 149°F)
Continuous operation (for altitude less than 950 m or 3117 ft)	10°C to 35°C (50°F to 95°F) with no direct sunlight on the equipment.
Maximum temperature gradient (operating and storage)	20°C/h (68°F/h)

Table 4: Relative Humidity Specifications

The table below shows the relative humidity specification during operations and storage.

Relative Humidity	Specifications
Storage	5% to 95% RH with 27°C (81°F) maximum dew point. Atmosphere must be non-condensing at all times.
Operating	8% relative humidity with -12°C to 80% relative humidity with 21°C (70°F) maximum dew point.

Table 5: Maximum Vibration Specifications

The table below shows the maximum vibration specifications during operations and storage.

Maximum Vibration	Specifications
Operating	0.26 Grms at 5 Hz to 350 Hz (all operation orientations).
Storage	1.88 Grms at 10 Hz to 500 Hz for 15 min (all six sides tested).

Table 6: Maximum Shock Specifications

The table below shows the maximum shock specifications during operations and storage.

Maximum Shock	Specifications
Operating	Six consecutively executed shock pulses in the positive and negative x, y, and z axes of 6 G for up to 11 ms.
Storage	Six consecutively executed shock pulses in the positive and negative x, y, and z axes (one pulse on each side of the system) of 71 G for up to 2 ms.

Table 7: Maximum Altitude Specifications



The table below shows the maximum altitude specifications during operations and storage.

Maximum Altitude	Specifications
Operating	3048 m (10,000 ft)
Storage	12,000 m (39,370 ft)

Table 8: Standard Operating Temperature

Standard Operating Temperature	Specifications
Continuous operation (for altitude less than 950 m or 3117 ft).	10°C to 35°C (50°F to 95°F) with no direct sunlight on the equipment.

Table 9: Expanded Operating Temperature

Expanded Operating Temperature	Specifications
Continuous operation	5°C to 40°C at 5% to 85% RH with 29°C dew point. <div style="border: 1px solid black; padding: 5px;">  Note: Outside the standard operating temperature (10°C to 40°C), the system can operate continuously in temperatures as low as 5°C and as high as 40°C. </div>
1% of annual operating hours	-5°C to 45°C at 5% to 90% RH with 29°C dew point. <div style="border: 1px solid black; padding: 5px;">  Note: Outside the standard operating temperature (10°C to 40°C), the system can operate down to -5°C or up to 45°C for a maximum of 1% of its annual operating hours. </div> <p>For temperatures between 40°C and 45°C, de-rate the maximum allowable temperature by 1°C per 125 m above 950 m (1°F per 228 ft).</p>

Expanded operating temperature restrictions

- Do not perform a cold start-up below 5°C.
- The operating temperature specified is for a maximum altitude of 3048 m (10,000 ft).
- 105 W/4C, 115 W/6C, 130 W/8C, 140 W/14C or higher wattage processor (TDP>140 W) are not supported.
- Redundant power supply configuration is required.
- Non-Arista-qualified peripheral cards and/or peripheral cards greater than 25 W are not supported.
- NVMe drives are not supported.
- Apache Pass DIMM and NVDIMM are not supported.

Table 10: Operating Temperature De-rating Specifications

The table below shows the operating temperature de-rating specifications.

Operating Temperature De-rating	Specifications
Up to 35°C (95°F)	Maximum temperature is reduced by 1°C/300 m (1°F/547 ft) above 950 m (3,117 ft).
35°C to 40°C (95°F to 104°F)	Maximum temperature is reduced by 1°C/175 m (1°F/319 ft) above 950 m (3,117 ft).
40°C to 45°C (104°F to 113°F)	Maximum temperature is reduced by 1°C/125 m (1°F/228 ft) above 950 m (3,117 ft).

Setup Preparation

This chapter discusses the following topics:

- [Site Selection](#)
- [Receiving and Inspecting the Equipment](#)
- [Electrostatic Discharge \(ESD\) Precautions](#)
- [Setting up Your System](#)
- [CloudVision AGNI Appliance Setup](#)
- [CloudVision AGNI Appliance IP Configuration](#)

2.1 Site Selection

Before you begin, read the safety instructions in your *Safety, Environmental, and Regulatory Information* booklet.

Consider the following criteria when selecting a site to install the appliance:

- Before you begin, review the safety instructions located at <https://www.arista.com/en/support/product-documentation>.
- Begin installing the rails in the allotted space closest to the bottom of the rack enclosure.
- Other Requirements: Select a site where liquids or objects cannot fall onto the equipment and foreign objects are not drawn into the ventilation holes. Verify these guidelines are met:
 - Clearance areas to the front and rear panels allow for unrestricted cabling.
 - All front and rear panel indicators can be easily read.
 - Power cords can reach from the power outlet to the connector on the rear panel.



Note: All power connections must be removed to de-energize the unit.



Note: This unit is intended for installation in restricted access areas.

2.2 Receiving and Inspecting the Equipment

Upon receiving the appliance, inspect the shipping boxes and record any external damage. Retain packing materials if you suspect that part of the shipment is damaged; the carrier may need to inspect them.

If the boxes were not damaged in transit, unpack them carefully. Ensure you do not discard any accessories packaged in the same box as the main unit.

Inspect the packing list and confirm that you received all listed items. Compare the packing list with your purchase order. The Appendix provides a list of components included with the appliance.

2.3 Electrostatic Discharge (ESD) Precautions

Adhere to these guidelines to avoid ESD damage when installing or servicing the appliance.

- Assemble or disassemble equipment only in a static-free work area.
- Select a conductive work surface (such as an anti-static mat) that dissipates static charge.
- Wear a conductive wrist strap to dissipate static charge accumulation.
- Minimize handling of assemblies and components.
- Keep replacement parts in their original static-free packaging.
- Remove all plastic, foam, vinyl, paper, and other static-generating materials from the work area.
- Select tools that do not create ESD.

2.4 Setting up Your System

Complete the following steps to set up your system:

1. Unpack the system.
2. Remove the I/O connector cover from the system connectors.



Note: While installing the system, ensure that it is properly aligned with the slot on the enclosure to prevent damage to the system connectors.

3. Install the system in the enclosure.
4. Turn on the enclosure.



Note: Wait for the chassis to initialize before you press the power button.

5. Press the power button on the system.

Alternatively, you can also turn on the system by using:

- The system iDRAC. For more information, see [Web Access into iDRAC \(System IPMI\)](#).
- The enclosure Chassis Management Controller (CMC), after the system iDRAC (IPMI) is configured on the CMC.

2.5 CloudVision AGNI Appliance Setup

You may need the following items to perform the procedures in this section:

- Key to the system key lock.
- #1 and #2 Phillips screwdriver.
- Wrist grounding strap connected to ground.
- The rack mount kit instructions are located in the shipping box.

Before Working Inside your System

Follow these safety guidelines: [Safety Information](#).

1. Turn off the system, including all attached peripherals.
2. Disconnect the system from the electrical outlet and disconnect the peripherals.
3. Remove the system cover.

2.5.1 Front Bezel

Complete the following tasks to remove the front bezel.

Figure 2-1: Front Bezel

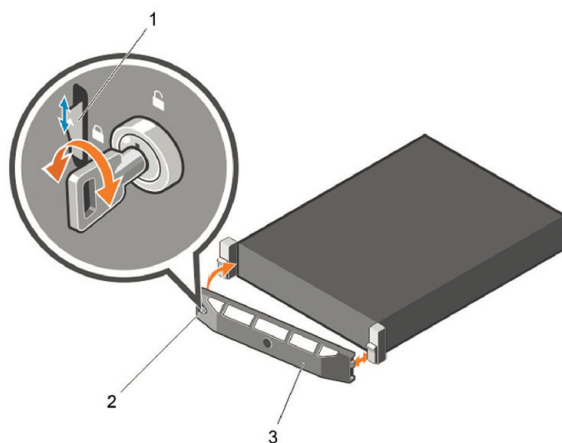

1. Unlock the key lock at the left end of the bezel.
2. Lift the release latch next to the key lock.
3. Rotate the left end of the bezel away from the front panel.
4. Unhook the right end of the bezel and pull the bezel away from the system.

2.5.2 Locate the MAC Addresses for the AGNI Appliance

The information tag is a slide-out label, which contains system information such as Service Tag, NIC, and MAC address for your reference. Record the MAC addresses in the CloudVision Worksheet.

Figure 2-2: Locating MAC Address of your System

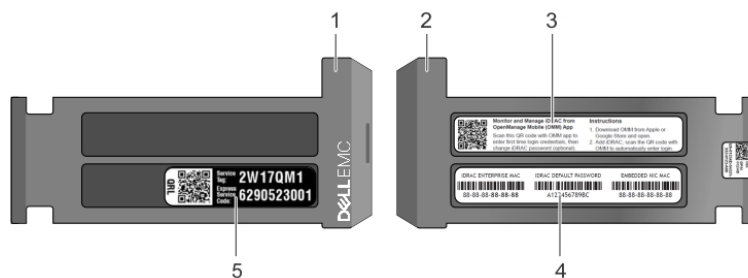

- | | | |
|---|-------------------------------|---------------------------------|
| 1 Information tag (front view) | 2 Information tag (back view) | 3 OpenManage Mobile (OMM) label |
| 4 iDRAC MAC address and iDRAC secure password label | 5 Service Tag | |

2.5.3 Rear Panel Ethernet Connections

On the back panel of the CloudVision AGNI appliance, locate the Ethernet Integrated 10/100/1000 Mbps NIC connectors.

Figure 2-3: Rear Panel

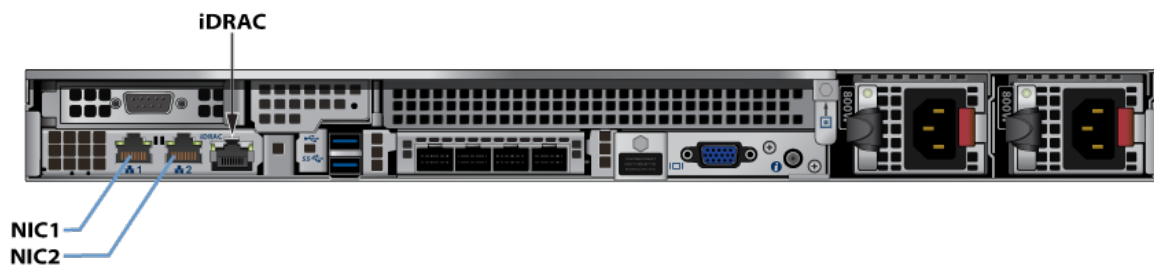

iDRAC is an Intelligent Platform Management Interface (IPMI) that provides a GUI-based out-of-band interface for monitoring the hardware appliance.

Record the IP address and Host name information on the CloudVision AGNI Worksheet.



Note: iDRAC may also be referred to as Life cycle Controller.

2.5.4 DNS Entries

To manage your CloudVision AGNI, it is easier to connect to them by host name instead of IP address. Fully Qualified Domain Names (FQDNs) should be allocated to:

- Each of the CloudVision AGNI Appliance host machines.
- Each of the CloudVision AGNI Appliance iDRAC interfaces.

Contact your DNS zone administrator for assistance.

2.6 CloudVision AGNI Appliance IP Configuration

The CloudVision AGNI Appliance Host and iDRAC IP addresses can be allocated in either of two ways:

Option 1: Using an available DHCP server

- DHCP Based IP Address Setup [DHCP Based IP Address Setup](#).
- Web Access into Host via iDRAC [Web Access into iDRAC \(System IPMI\)](#).

Option 2: Manual configuration (Requires terminal connected to VGA port)

- [Manual IP Address Setup](#) .
- Web Access into Host via iDRAC [Web Access into iDRAC \(System IPMI\)](#).

2.6.1 Setting up Manual IP Address

To setup manual IP address:

1. Turn on the managed system.
2. Press <F2> during the Power-on Self-test (POST).

Figure 2-4: Power-On Self-Test



3. In the System Setup Main Menu, click **iDRAC Settings**.

Figure 2-5: System Setup Main Menu

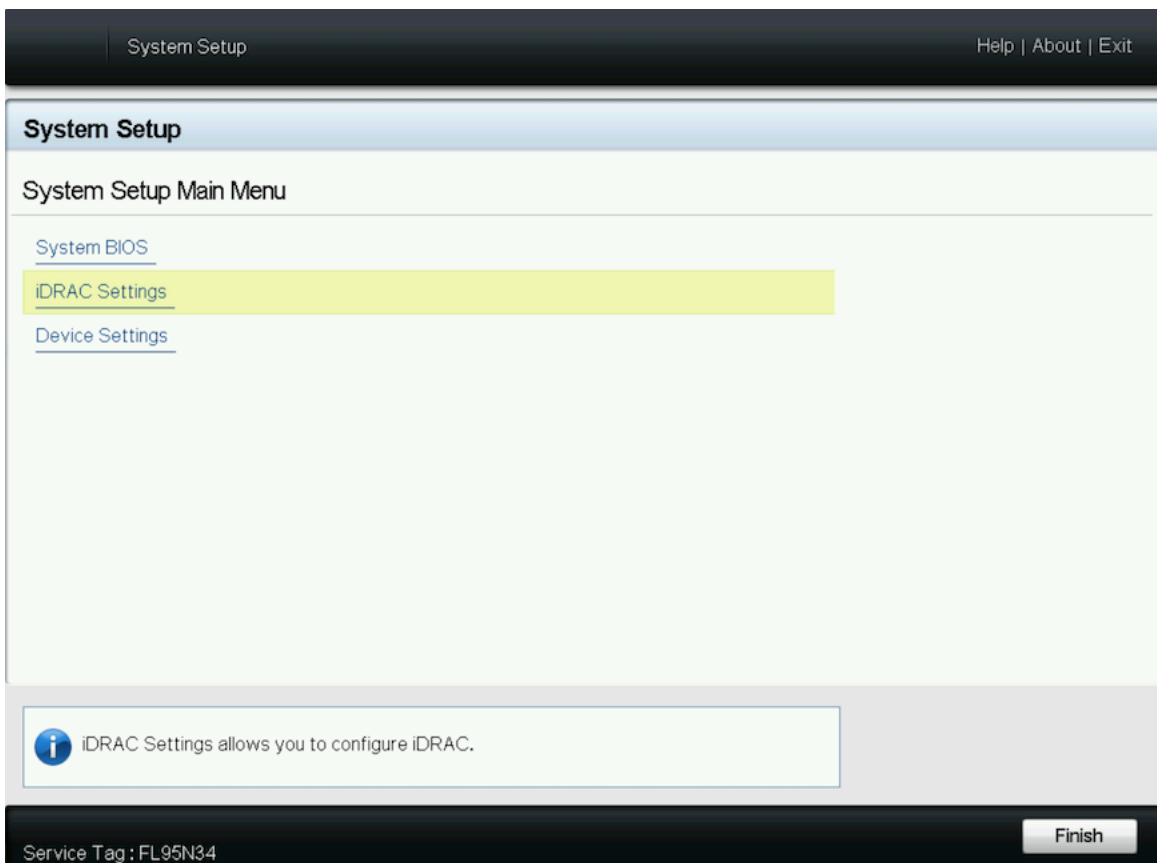

The **iDRAC Settings** page is displayed.

4. Click **Network**.

Figure 2-6: iDRAC Settings page

The screenshot displays the iDRAC Settings page. At the top, there is a dark header bar with "System Setup" on the left and "Help | About | Exit" on the right. Below this is a light blue bar with the text "iDRAC Settings". The main content area is white and contains the following elements:

- iDRAC Settings** (Section Header)
- iDRAC Settings Version 5.00.00.17
- iDRAC Firmware Version 7.10.30.00 (Build 30)
- [System Summary](#)
- [System Event Log](#)
- Network** (This section is highlighted with a yellow background)
- [Alerts](#)
- [Front Panel Security](#)
- [Media and USB Port Settings](#)
- [Lifecycle Controller](#)
- [Hardware Configuration Validation](#)

At the bottom of the main content area, there is a grey box with an information icon (i) and the text: "Use this page to configure the network properties, common iDRAC settings, IPv4 and IPv6 properties, IPMI settings, and VLAN settings."

The footer of the page is dark and contains "Service Tag : FL95N34" on the left and a "Finish" button on the right.

The Network page is displayed.

Figure 2-7: iDRAC Settings Network

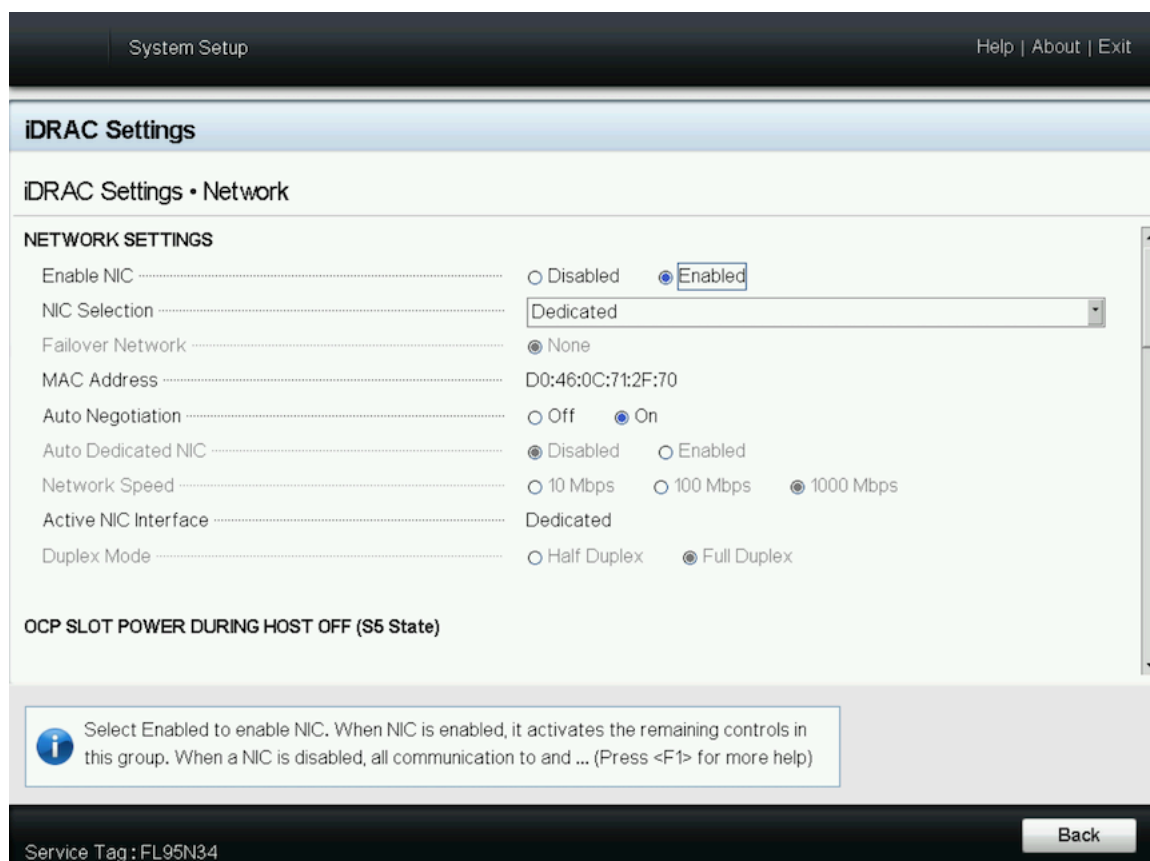

Scroll down in the iDRAC Settings Network page to the Common Settings section.

5.  **Note:** If a network infrastructure has a DNS server, register iDRAC on the DNS. The following are the initial setting requirements for advanced features such as Directory services—Active Directory or LDAP, Single Sign On, and smart card.

To register iDRAC:

- a. Enable **Register DRAC on DNS**.
 - b. Enter the **DNS DRAC Name**.
 - c. Enable **Auto Config Domain Name** to automatically acquire the domain name from the **DHCP**. Alternatively, provide the **Static DNS Domain Name**.
6. Configure the IPv4 Settings:
- a. **Enable IPv4** option.
 - b. **Enable DHCP** to automatically assign the IP Address, Gateway, and Subnet Mask to iDRAC. Alternatively, disable the DHCP and enter the values:
 - c. Alternatively, disable the **Enable DHCP** option and enter the values for:
 1. **Static IP Address**

2. **Static Gateway**
3. **Static Subnet Mask**

Figure 2-8: iDRAC Settings: Common & IPv4 Settings

System Setup Help | About | Exit

iDRAC Settings

iDRAC Settings • Network

COMMON SETTINGS

Register DRAC on DNS	<input type="radio"/> Disabled <input checked="" type="radio"/> Enabled
DNS DRAC Name	<input type="text" value="idrac-FL95N34"/>
Auto Config Domain Name	<input type="radio"/> Disabled <input checked="" type="radio"/> Enabled
Static DNS Domain Name	<input type="text" value="aristanetworks.com"/>

IPV4 SETTINGS

Enable IPv4	<input type="radio"/> Disabled <input checked="" type="radio"/> Enabled
Enable DHCP	<input type="radio"/> Disabled <input checked="" type="radio"/> Enabled
IP Address	<input type="text" value="10.87.137.193"/>
Gateway	<input type="text" value="10.87.137.1"/>
Subnet Mask	<input type="text" value="255.255.255.0"/>

 Select Enabled to register the iDRAC address with the Domain Name Server (DNS).

Service Tag : FL95N34

7. Click the **Back** button.
8. Click the **Finish** button. The Save Changes pop-up window is displayed:

Figure 2-9: Save Changes Window

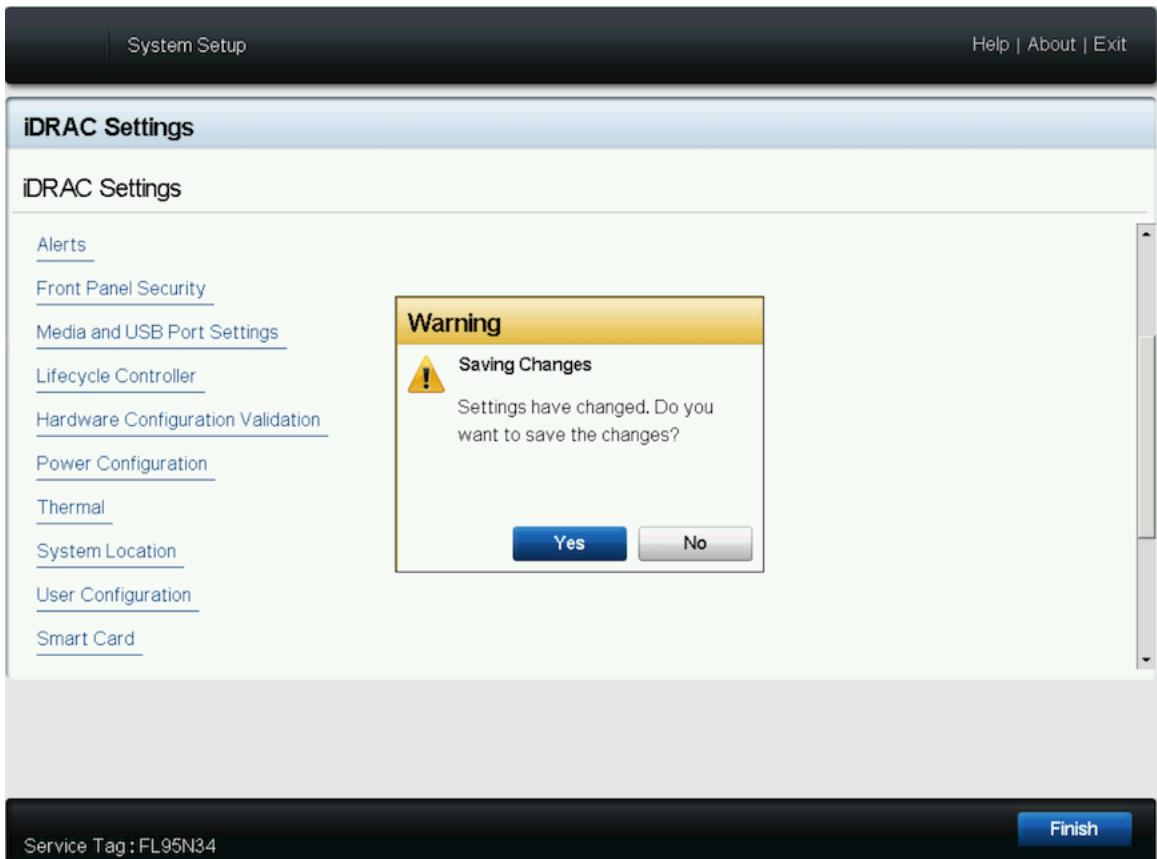

9. Click the **Yes** button to save the changes. The network information is saved and the system reboots.

Figure 2-10: Save Settings window

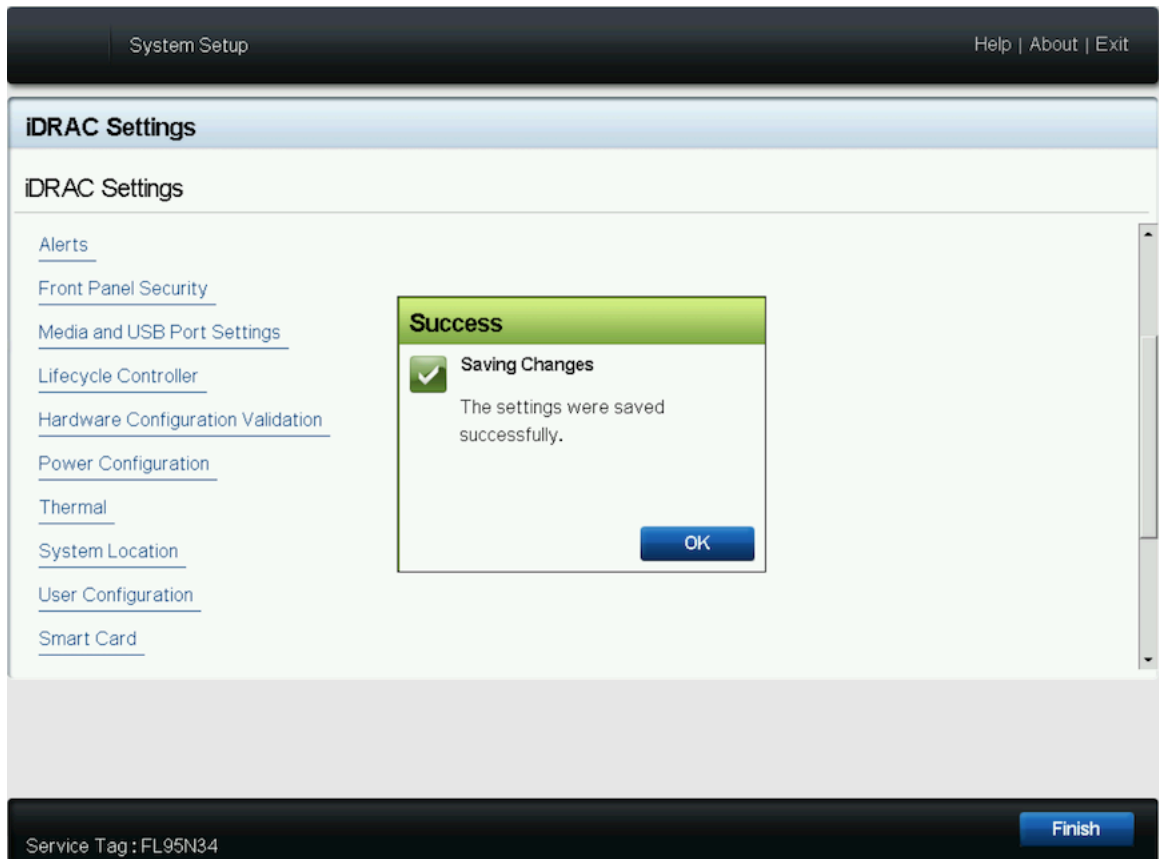

Note: Direct IP Address Setup requires a terminal connected to the VGA port of the appliance. This section can be skipped if the Host and iDRAC IP addresses have been configured with a DHCP server.

CloudVision AGNI Appliance Access

This section discusses the following topic:

- [iDRAC](#)

3.1 iDRAC

iDRAC is a GUI based IPMI running on a separate out of band CPU used for monitoring the hardware appliance.

- [Web Access into iDRAC \(System IPMI\)](#)
- [Changing the iDRAC Password](#)
- [Updating the Host Password](#)

3.1.1 Web Access into iDRAC (System IPMI)

iDRAC is supported on the following browsers:

- **Mozilla Firefox**
- **Google Chrome**
- **Safari**
- **Microsoft Edge**

On the management station, open the Web browser and connect to the iDRAC7 using: `https://<hostname or IP of iDRAC>`.

For example: `https://192.168.0.120`.

The Login page appears.

Figure 3-1: iDRAC Login Page

Integrated Remote Access Controller 9
idrac-FL95N34 | Enterprise

Type the User Name and Password and click Log In.

Username:

Password:

Domain:

Security Notice: By accessing this computer, you confirm that such access complies with your organization's security policy.

[Help](#) | [Support](#)

Login using the default username and password, which are:

- Username: **root**
- Password: **arista**



Note: Both the username and password are case sensitive.

3.1.2 Updating the Host Password

You can directly update or change a password using the following method.

Log in to iDRAC using a web console using iDRAC credentials. Navigate to **Virtual Console** and access the Host console.

Figure 3-2: Access Virtual Console

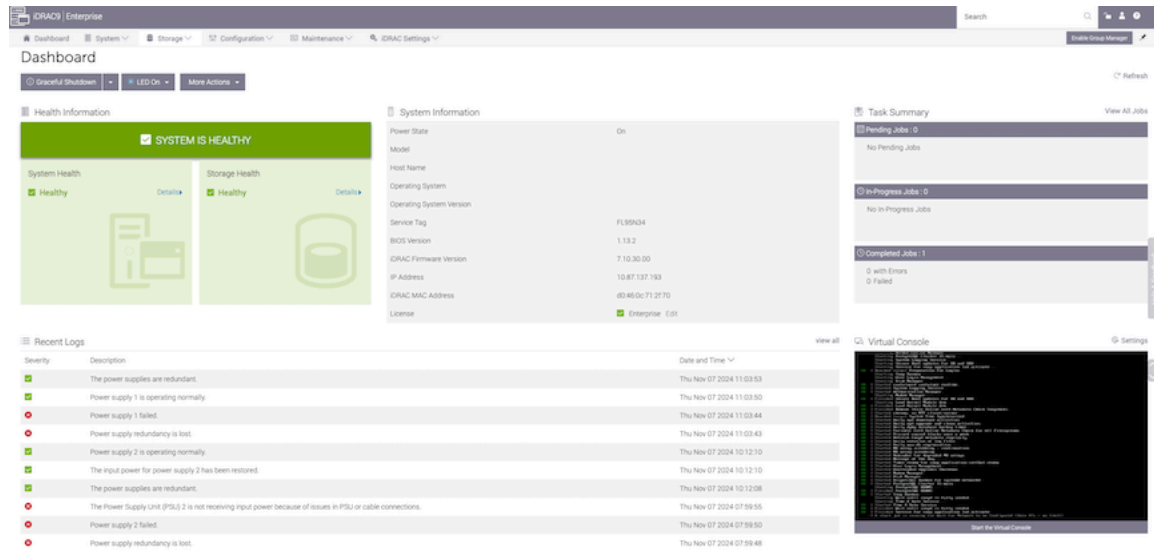

Enter the default login credentials. For details, see the DCA-AGNI-100 Appliance Setup & Access Guide on Arista website.

3.1.3 Changing iDRAC Password

To change the password through the iDRAC web interface, complete the following steps:

1. Press F2 during system POST to access the System Settings page. Select the **iDRAC Settings**.

Figure 3-3: System Setup

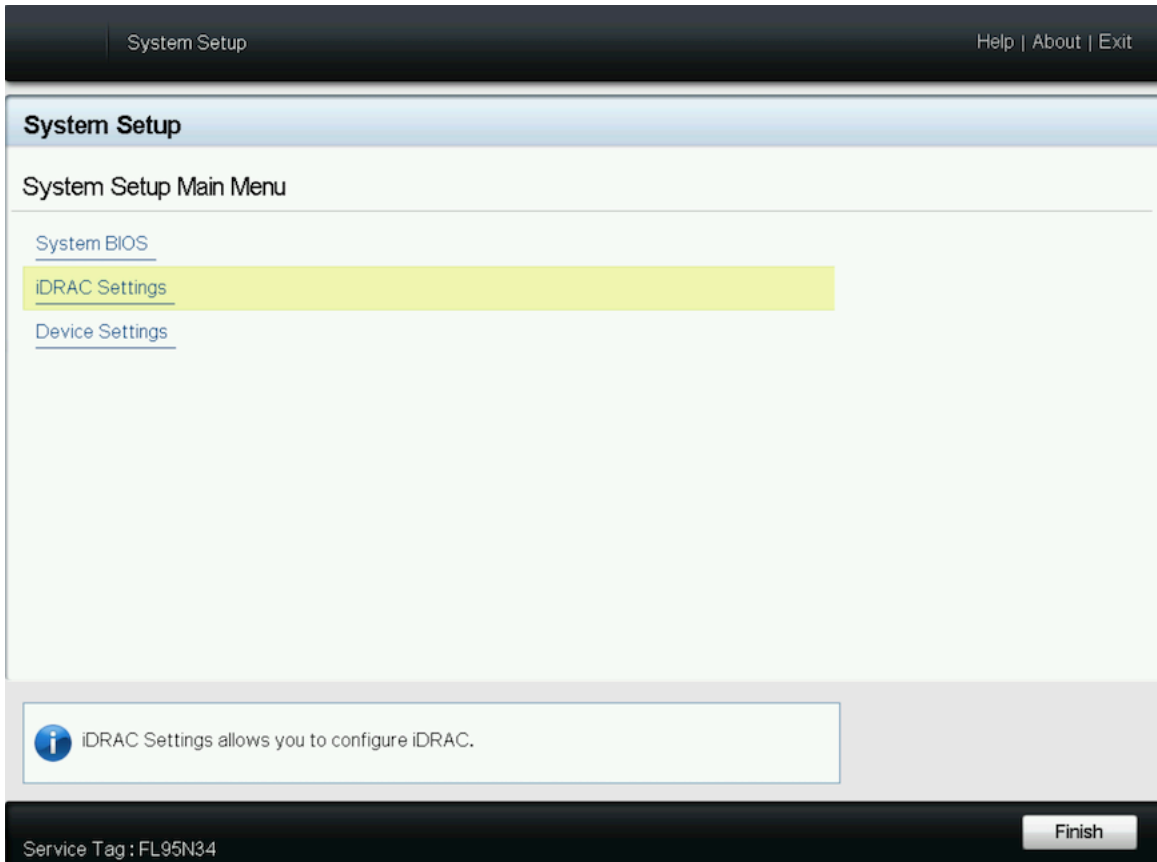

2. In the iDRAC Settings page, go to **User Configuration**.

Figure 3-4: iDRAC Settings Page

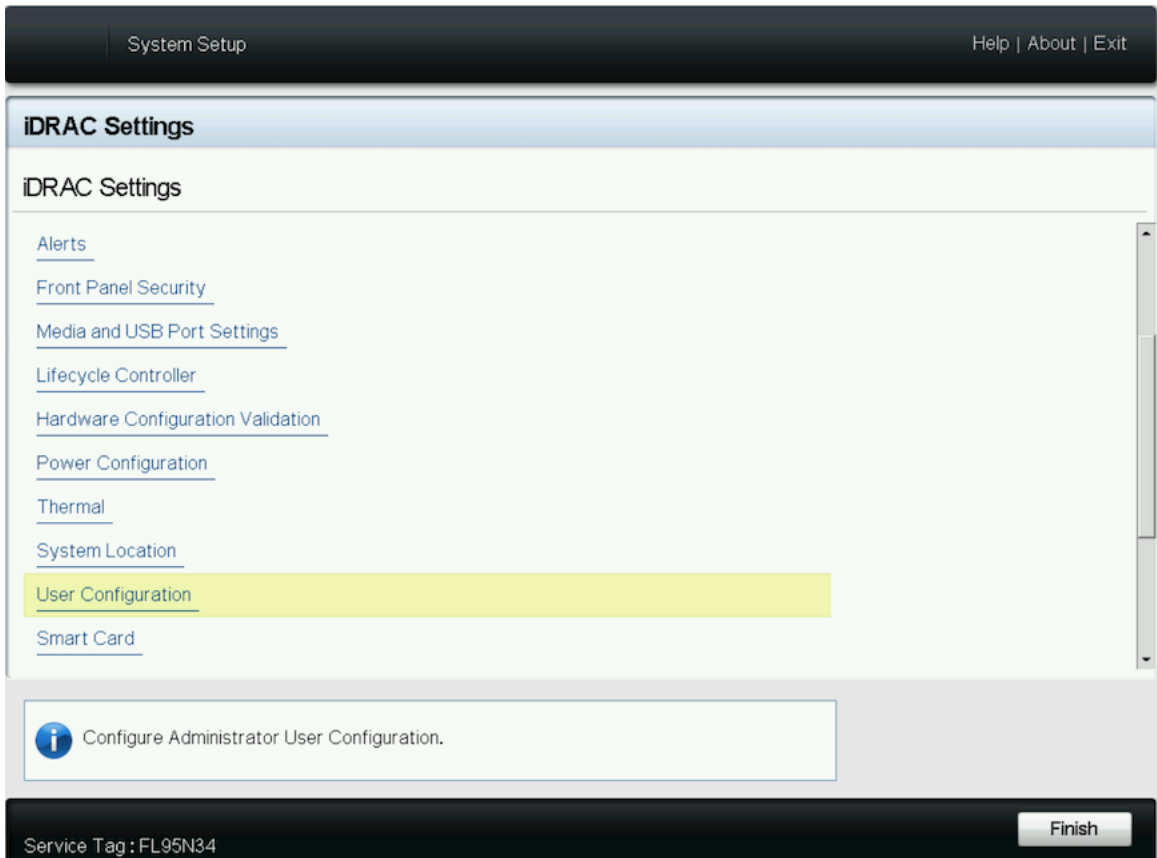

The iDRAC Settings User Configuration page is displayed.

3. Enter the new password in the **Change Password** field.

Figure 3-5: iDRAC Setting - User Configuration Page

System Setup Help | About | Exit

iDRAC Settings

iDRAC Settings • User Configuration

User ID	2
Enable User	<input type="radio"/> Disabled <input checked="" type="radio"/> Enabled
User Name	<input type="text" value="root"/>
LAN User Privilege	<input type="text" value="Administrator"/>
Serial Port User Privilege	<input type="text" value="Administrator"/>
Change Password	<input type="text" value="Press <Enter> to input"/>

 Enter a password with up to 20 characters. The characters are masked. The following characters are supported: 0-9, A-Z, a-z, Special characters: ... (Press <F1> for more help)

Service Tag: FL95N34

4. Type the new password and then click **OK** button or press Enter.

Figure 3-6: Confirm New Password

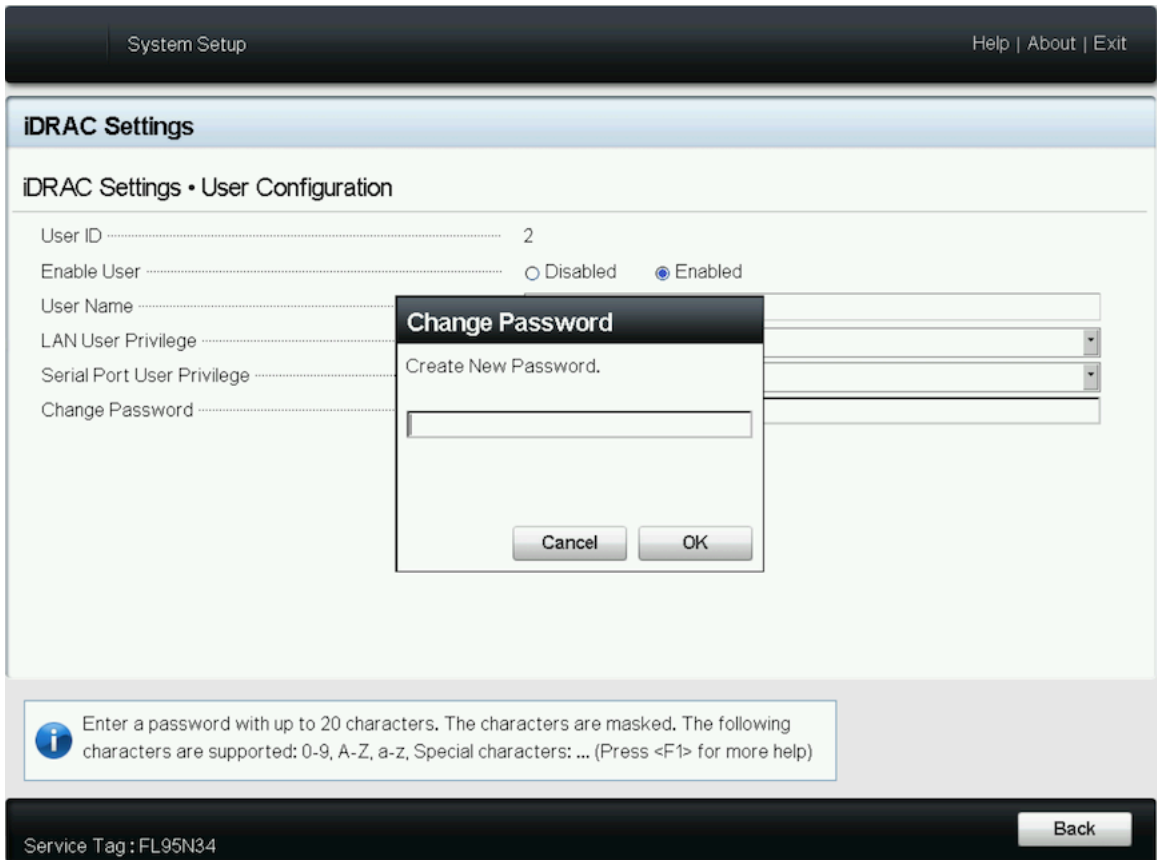

- 5. Click the **Back** button or press Enter after changing the password.

Figure 3-7: Password Change

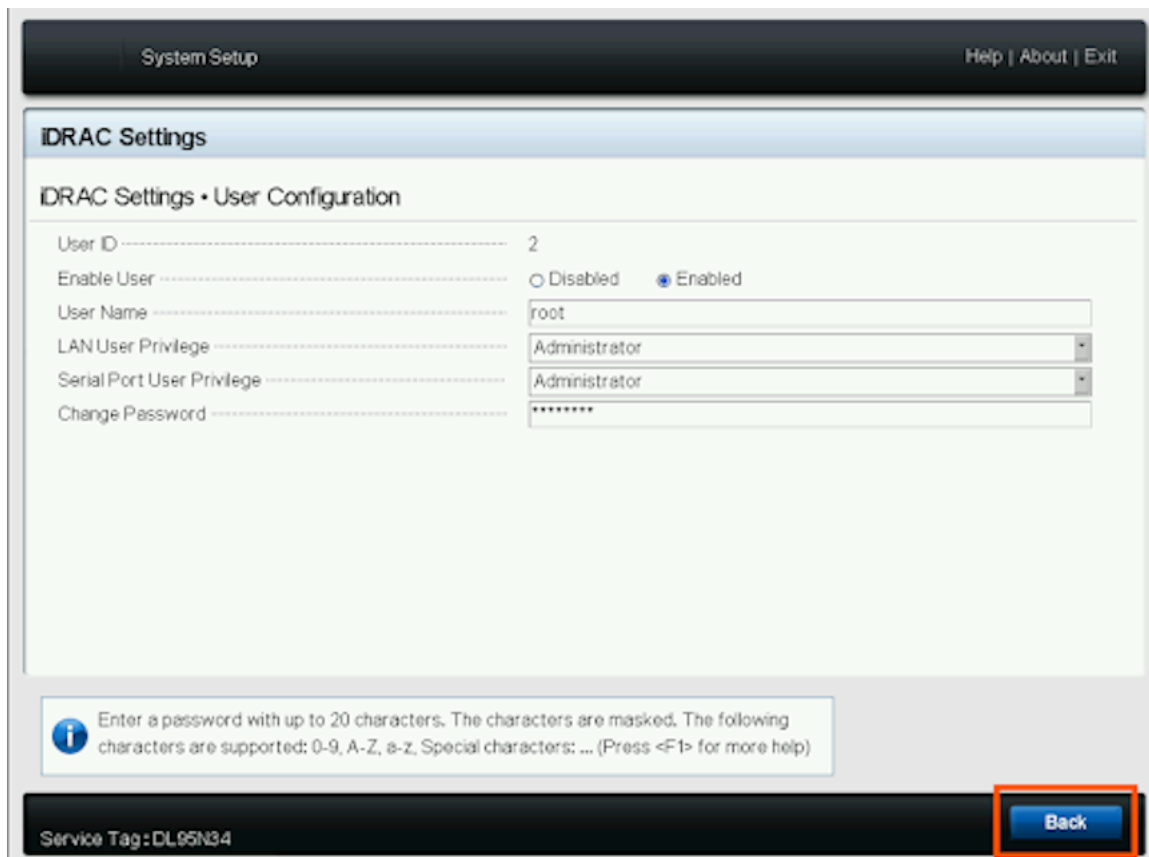

6. Click **Finish** or press Enter.

Figure 3-8: iDRAC Settings

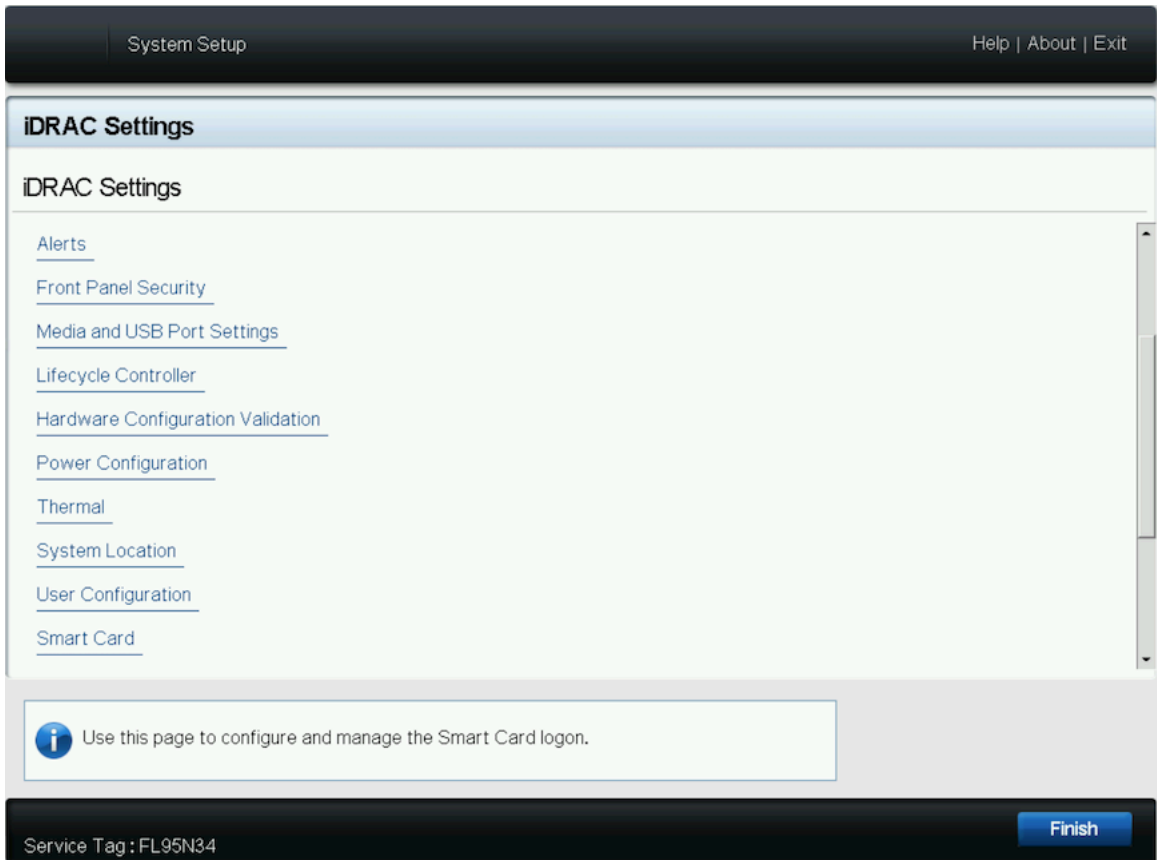

7. Click **Yes** or press Enter to confirm the changes.

Figure 3-9: Save Changes

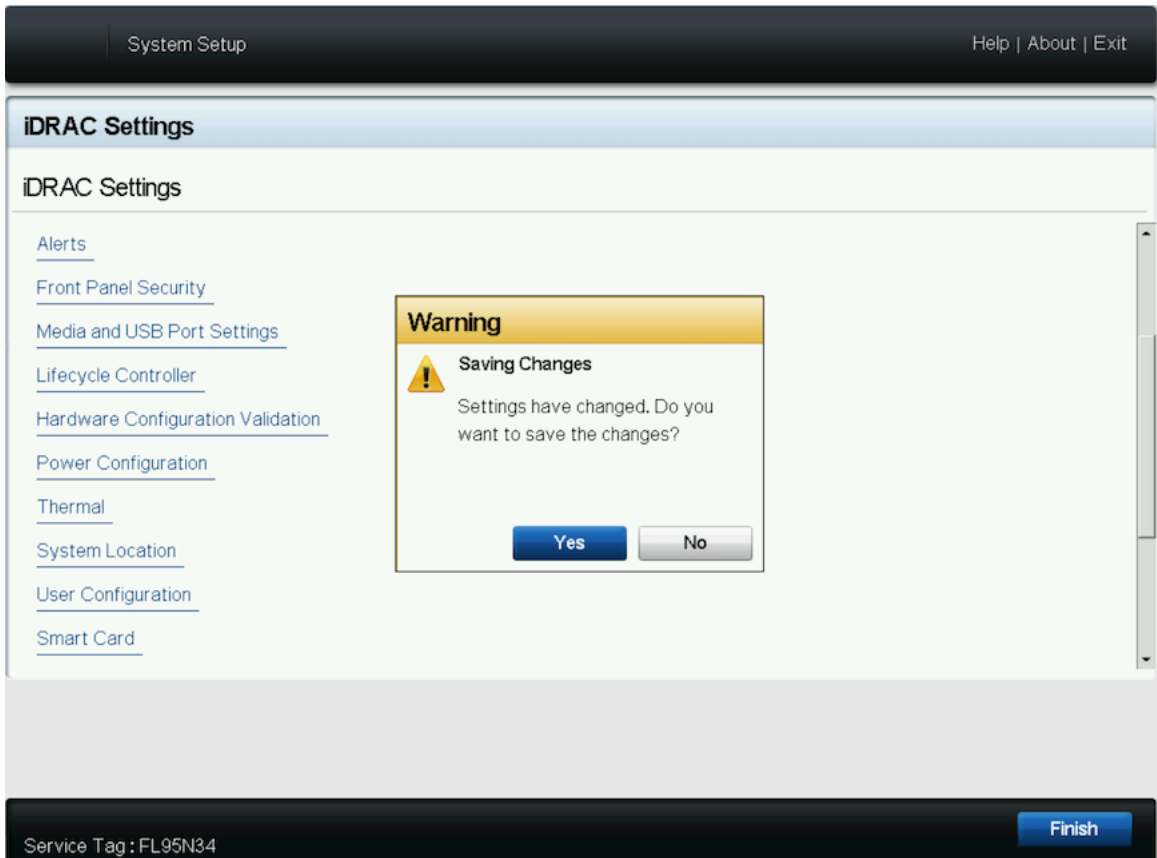

8. Click **OK** or press Enter at the confirmation prompt.

Figure 3-10: Confirm Changes

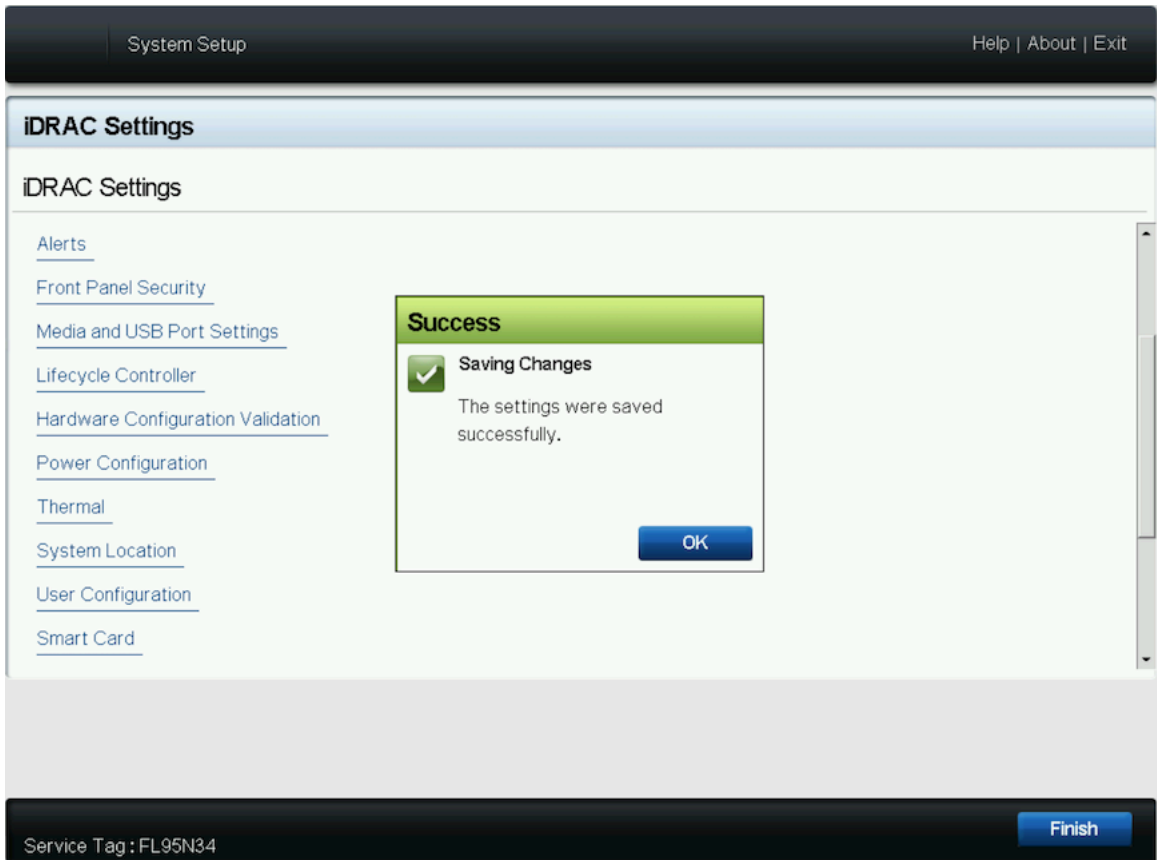

9. Click **Finish** or press Enter.

Figure 3-11: Click Finish Button

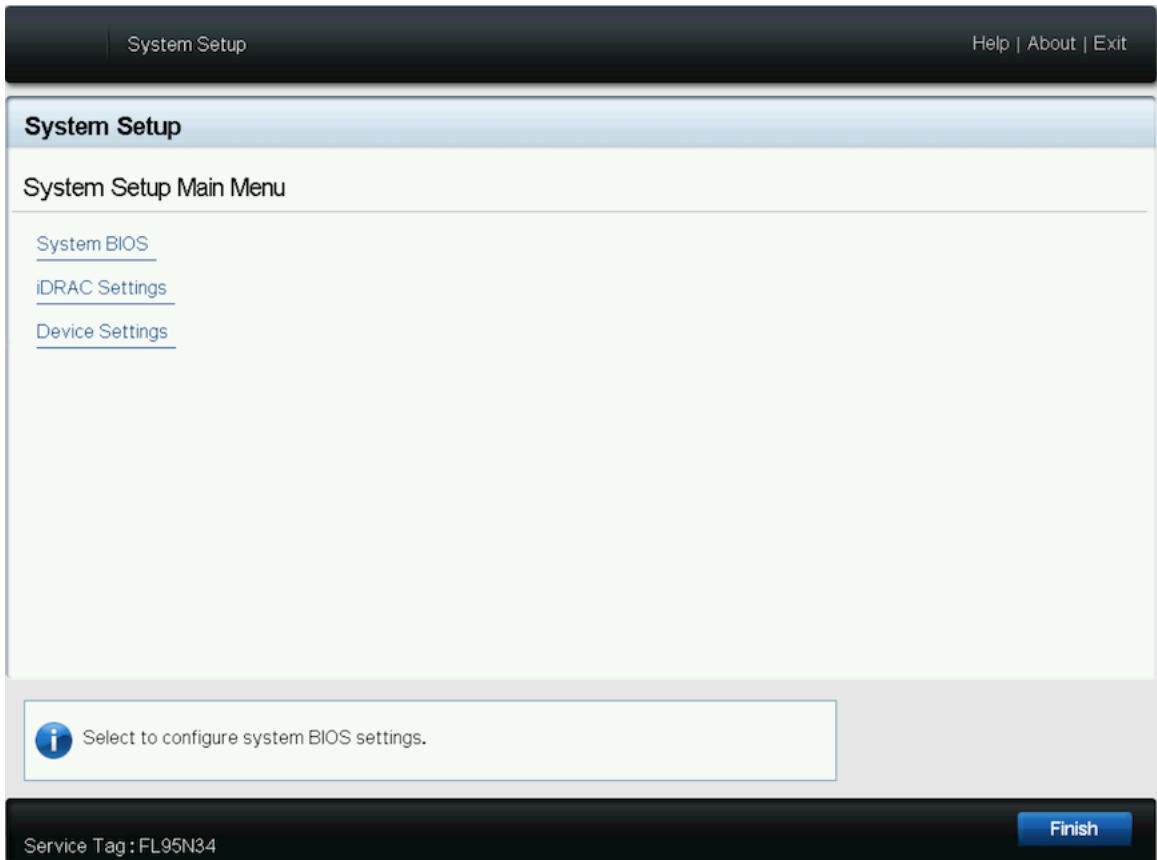

Series Status Indicators

This section discusses the following topics:

- [LCD Panel Features](#)
- [Status LED Indicators](#)
- [NIC Indicator Codes](#)
- [Power Supply Unit Indicator Codes](#)

4.1 LCD Panel Features

The system's LCD panel provides system information and status and error messages to indicate if the system is operating correctly or if the system needs attention.

The LCD back-light lights blue during normal operating conditions.

When the system needs attention, the LCD lights amber and displays an error code followed by descriptive text.



Note: If the system is connected to a power source and an error is detected, the LCD lights amber regardless of whether the system is turned on or off.

The LCD back-light turns OFF when the system is in standby mode and can be turned on by pressing either the Select, Left, or Right button on the LCD panel.

The LCD back-light remains OFF if LCD messaging is turned off through the iDRAC utility, the LCD panel, or other tools.

Figure 4-1: LCD Panel Features

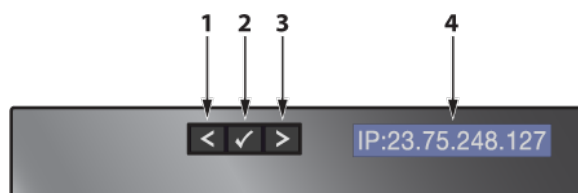

Table 11: LCD Panel Features Description





Item	Button	Description
1	Left	Moves the cursor back in one-step increments.
2	Select	Selects the menu item highlighted by the cursor.
3	Right	Moves the cursor forward in one-step increments. During message scrolling: <ul style="list-style-type: none">• Press once to increase scrolling speed.• Press again to return to the default scrolling speed.• Press again to repeat the cycle.• Press again to stop.
4	IP	Displays the IP Address panel.

4.2 Status LED Indicators



Note: The indicators display solid amber if any error occurs.

Table 12: Status LED Indicators and Descriptions

Icon	Description	Condition	Corrective Action
	Drive Indicator	The indicator turns solid amber if there is a drive error.	<ul style="list-style-type: none"> • Check the System Event Log to determine if the drive has an error. • Run the appropriate Online Diagnostics test. Restart the system and run embedded diagnostics (ePSA). • If the drives are configured in a RAID array, restart the system, and enter the host adapter configuration utility program.
	Temperature Indicator	The indicator turns solid amber if the system experiences a thermal error (for example, the ambient temperature is out of range, or there is a fan failure).	<p>Ensure that none of the following conditions exist:</p> <ul style="list-style-type: none"> • A cooling fan has been removed or has failed. • System cover, air shroud, memory module blank, or back filler bracket is removed. • Ambient temperature is too high. • External airflow is obstructed.
	Electrical Indicator	The indicator turns solid amber if the system experiences an electrical error (for example, voltage out of range, or a failed power supply unit (PSU) or voltage regulator).	Check the System Event Log or system messages for the specific issue. If it is due to a problem with the PSU, check the LED on the PSU. Reseat the PSU.
	Memory Indicator	The indicator turns solid amber if a memory error occurs.	Check the System Event Log or system messages for the location of the failed memory. Reseat the memory module.
	PCIe Indicator	The indicator turns solid amber if a PCIe card experiences an error.	Restart the system. Update any required drivers for the PCIe card. Reinstall the card.

4.2.1 iDRAC Direct LED Indicator Codes

The iDRAC Direct LED indicator lights up to indicate that the port is connected and is being used as a part of the iDRAC subsystem.

You can configure iDRAC Direct by using a USB to micro USB (type AB) cable, which you can connect to your laptop or tablet. The following table describes iDRAC Direct activity when the iDRAC Direct port is active:

Table 13: iDRAC Direct LED Indicator Codes

iDRAC Direct LED Indicator Code	Condition
Solid green for two seconds.	Indicates that the laptop or tablet is connected.
Flashing green (on for two seconds and off for two seconds).	Indicates that the laptop or tablet connected is recognized.
Turns off.	Indicates that the laptop or tablet is unplugged.

4.2.1.1 iDRAC Quick Sync 2 Indicator Codes

iDRAC Quick Sync 2 module (optional) is located on the left control panel of your system.

Figure 4-2: iDRAC Quick Sync 2 Indicator

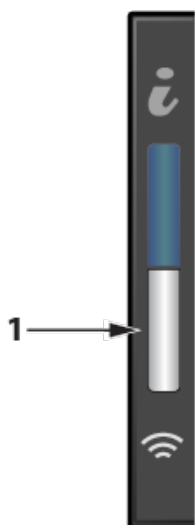

Table 14: iDRAC Quick Sync 2 Indicators and Descriptions

iDRAC Quick Sync 2 indicator code (1)	Condition	Corrective action
Off (default state)	Indicates that the iDRAC Quick Sync 2 feature is turned off. Press the iDRAC Quick Sync 2 button to turn on the iDRAC Quick Sync 2 feature.	If the LED fails to turn on, reseal the left control panel flex cable and check.
Solid white	Indicates that iDRAC Quick Sync 2 is ready to communicate. Press the iDRAC Quick Sync 2 button to turn off.	If the LED fails to turn off, restart the system.
Blinks white rapidly	Indicates data transfer activity.	
Blinks white slowly	Indicates that firmware update is in progress.	
Blinks white five times rapidly and then turns off	Indicates that the iDRAC Quick Sync 2 feature is disabled.	Check if iDRAC Quick Sync 2 feature is configured to be disabled by iDRAC.
Solid amber	Indicates that the system is in fail-safe mode.	Restart the system.
Blinking amber	Indicates that the iDRAC Quick Sync 2 hardware is not responding properly.	Restart the system.

4.2.2 NIC Indicator Codes

Each NIC on the back of the system has indicators that provide information about the activity and link status. The activity LED indicator indicates if data is flowing through the NIC, and the link LED indicator indicates the speed of the connected network.

Figure 4-3: NIC Status Indicator

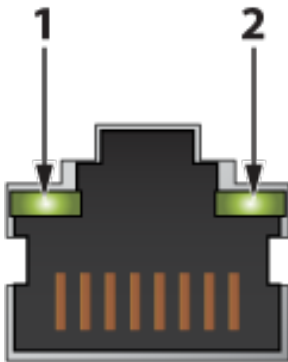

1 Link LED indicator

2 Activity LED indicator

Table 15: NIC Indicator Codes

Status	Condition
Link and activity indicators are off.	The NIC is not connected to the network.
Link indicator is green, and activity indicator is blinking green.	The NIC is connected to a valid network at its maximum port speed and data is being sent or received.
Link indicator is amber and activity indicator is blinking green.	The NIC is connected to a valid network at less than its maximum port speed and data is being sent or received.
Link indicator is green, and activity indicator is off.	The NIC is connected to a valid network at its maximum port speed and data is not being sent or received.
Link indicator is amber and activity indicator is off.	The NIC is connected to a valid network at less than its maximum port speed and data is not being sent or received.
Link indicator is blinking green and activity is off.	NIC identify is enabled through the NIC configuration utility.

4.2.3 Power Supply Unit Indicator Codes

AC power supply units (PSUs) have an illuminated translucent handle that serves as an indicator. The indicator shows whether power is present or if a power fault has occurred.

Figure 4-4: Power Supply unit Indicators

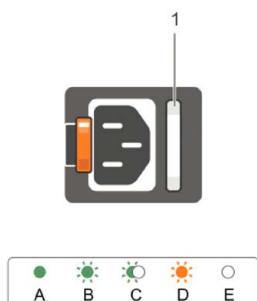

1 AC PSU status indicator/handle.

Table 16: AC PSU Status Indicator Codes

Power Indicator Codes	Condition
Green	A valid power source is connected to the PSU, and the PSU is operational.
Blinking amber	Indicates a problem with the PSU.
Not illuminated	Power is not connected to the PSU.
Blinking green	<p>When the firmware of the PSU is being updated, the PSU handle blinks green.</p> <div style="border: 1px solid black; padding: 5px;"> <p>CAUTION: Do not disconnect the power cord or unplug the PSU when updating the firmware. If the firmware update is interrupted; the PSUs do not function.</p> </div>
Blinking green and turns off	<p>When hot-plugging a PSU, the PSU handle blinks green five times at a rate of 4 Hz and turns off. This indicates a PSU mismatch concerning efficiency, feature set, health status, or supported voltage.</p> <div style="border: 1px solid black; padding: 5px;"> <p>CAUTION: If two PSUs are installed, both the PSUs must have the same type of label; for example, Extended Power Performance (EPP) label. Mixing PSUs from previous generations of PowerEdge servers is not supported, even if the PSUs have the same power rating. This results in a PSU mismatch condition or failure to turn the system on.</p> </div> <div style="border: 1px solid black; padding: 5px;"> <p>CAUTION: When correcting a PSU mismatch, replace only the PSU with the blinking indicator. Swapping the PSU to make a matched pair can result in an error condition and unexpected system shutdown. To change from a high output configuration to a low output configuration or vice versa, you must turn off the system.</p> </div> <div style="border: 1px solid black; padding: 5px;"> <p>CAUTION: AC PSUs support both 240 V and 120 V input voltages except for Titanium PSUs, which support only 240 V. When two identical PSUs receive different input voltages, they can output different wattage, and trigger a mismatch.</p> </div> <div style="border: 1px solid black; padding: 5px;"> <p>CAUTION: If two PSUs are used, they must be of the same type and have the same maximum output power.</p> </div>

Rack Installation

This section discusses the following topics:

- [Rack Installation](#)
- [Two-Post Rack Mount Parts](#)

5.1 Rack Installation

Use the following steps to assemble the racking rails and attach the components to the system.

1. Identifying the Rail Kit Contents.

Locate the components for installing the rail kit assembly:

- Two sliding rail assemblies.
- Two hook and loop straps.

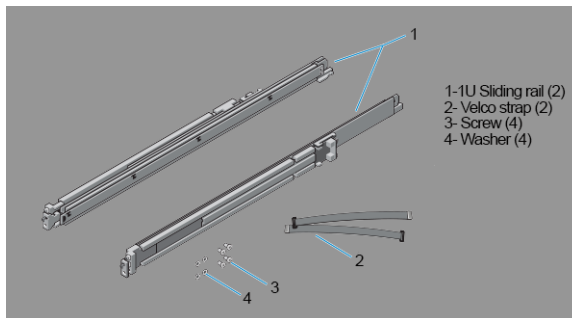

2. Installing and Removing Tool-less Rails (Square Hole or Round Hole Racks).

- a. Position the left and right rail end pieces labeled FRONT facing inward and orient each end piece to seat in the holes on the front side of the vertical rack flanges.
- b. Align each end piece in the bottom and top holes of the desired U spaces.
- c. Engage the back end of the rail until it fully seats on the vertical rack flange and the latch clicks into place. Repeat these steps to position and seat the front end piece on the vertical rack flange.
- d. To remove the rails, pull the latch release button on the end piece midpoint and unseat each rail

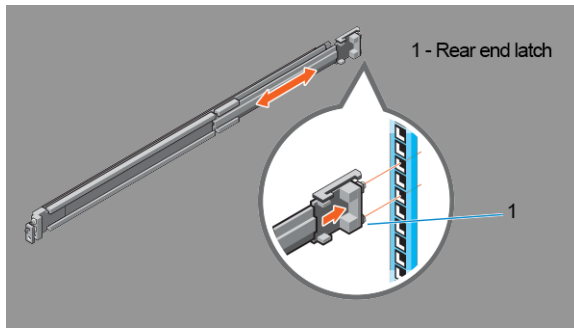

3. Installing and Removing Tooled Rails (Threaded Hole Racks).
 - a. Remove the pins from the front and rear mounting brackets using a flat-tipped screwdriver.
 - b. Pull and rotate the rail latch sub-assemblies to remove them from the mounting brackets.
 - c. Attach the left and right mounting rails to the front vertical rack flanges using two pairs of screws.
 - d. Slide the left and right back brackets forward against the rear vertical rack flanges and attach them using two pairs of screws.

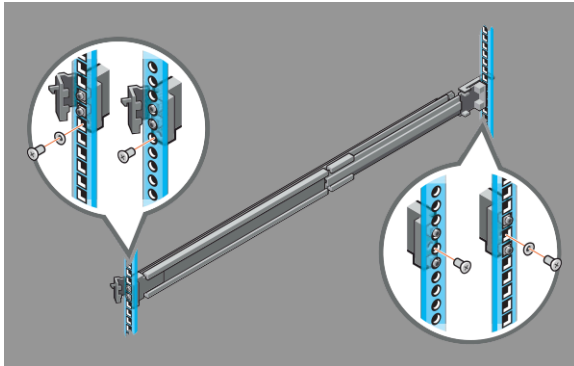

4. Installing the System in a Rack.
 - a. Pull the inner slide rails out of the rack until they lock into place.
 - b. Locate the rear rail standoff on each side of the system and lower them into the rear J-slots on the slide assemblies.
 - c. Rotate the system downward until all the rail standoffs are seated in the J-slots.
 - d. Push the system inward until the lock levers click into place. Press the slide-release lock buttons on both rails and slide the system into the rack.

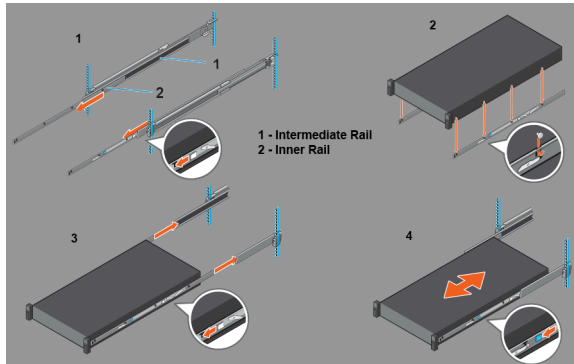

5. Removing the System From the Rack.

- a. Locate the lock levers on the sides of the inner rails.
- b. Unlock each lever by rotating it up to its release position.
- c. Grasp the sides of the system firmly and pull it forward until the rail standoffs are at the front of the J-slots. Lift the system up and away from the rack and place it on a level surface.

6. Engaging and Releasing the Slam Latch.



Note: For systems not equipped with slam latches, secure the system using screws, as described in **Step C** of this procedure.

- a. Facing the front, locate the slam latch on either side of the system.
- b. The latches engage automatically as the system is pushed into the rack and are released by pulling up on the latches.
- c. To secure the system for shipment in the rack or other unstable environments, locate the hard-mount screw under each latch and tighten each screw with a #2 Phillips screwdriver.

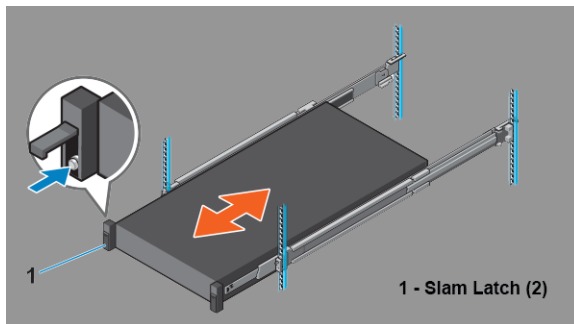

7. Routing the Cables.

- a. Locate the outer brackets on the interior sides of both rack flanges.
- b. Bundle the cables gently, pulling them from the system connectors to the left and right sides.
- c. Thread the hook and loop straps through the tooled slots on the outer brackets on each side of the system to secure the cable bundles.

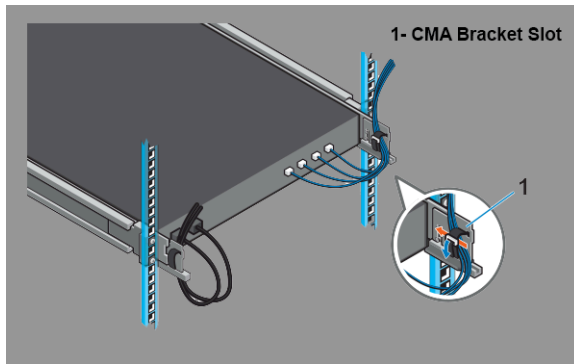

5.2 Two-Post Rack Mount Parts

The two-post rack mount kit includes:

- Two sliding rail assemblies.
- Two hook and loop straps.

Figure 5-1: Two-Post Rack Mount Parts

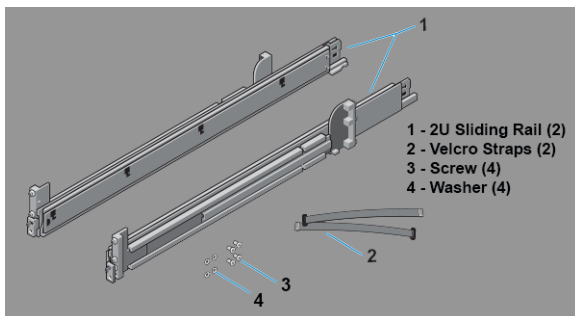

Front View of the System

This section discusses the following topic:

- [Front View of the System](#)

6.1 Front View of the System

This front view displays the features available on the front panel of the CloudVision AGNI Appliance.

Figure 6-1: Front Panel of DCA-AGNI-100

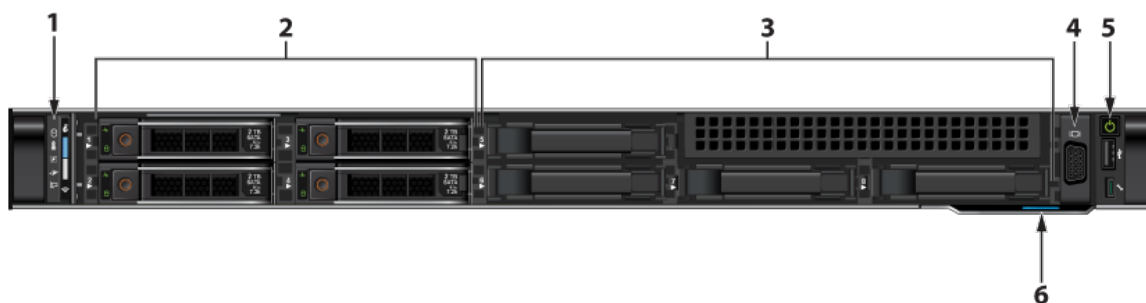

Table 17: Features Available on the Front Panel of DCA-AGNI-100

Item	Ports, panels, and slots	Description
1	Left control panel	<p>Contains the system health and system ID, status LED, and the iDRAC Quick Sync 2 (wireless) indicator.</p> <div style="border: 1px solid #ccc; padding: 5px; margin: 5px 0;"> <p>Note: The iDRAC Quick Sync 2 indicator is available only on certain configurations.</p> </div> <ul style="list-style-type: none"> • Status LED: Enables you to identify any failed hardware components. There are up to five status LEDs and an overall system health LED (Chassis health and system ID) bar. • Quick Sync 2 (wireless): Indicates a Quick Sync enabled system. The Quick Sync feature is optional. This feature allows management of the system by using mobile devices. This feature aggregates hardware or firmware inventory and various system level diagnostic and error information that can be used in troubleshooting the system.
2 and 3	Hard drive slots	8x2.5" hard drive/SSD slots.
4	VGA port	Allows you to connect a display to the system.
5	Right control panel	Contains the power button, USB port, iDRAC Direct micro port, and the iDRAC Direct status LED.
6	Information tag	A slide-out label panel which contains system information such as Service Tag, NIC, MAC address, for your reference.

Rear Panel Features and Indicators

This section displays the rear panel of the CloudVision AGNI Appliance.

Figure 7-1: DCA-AGNI-100 Appliance (rear view)

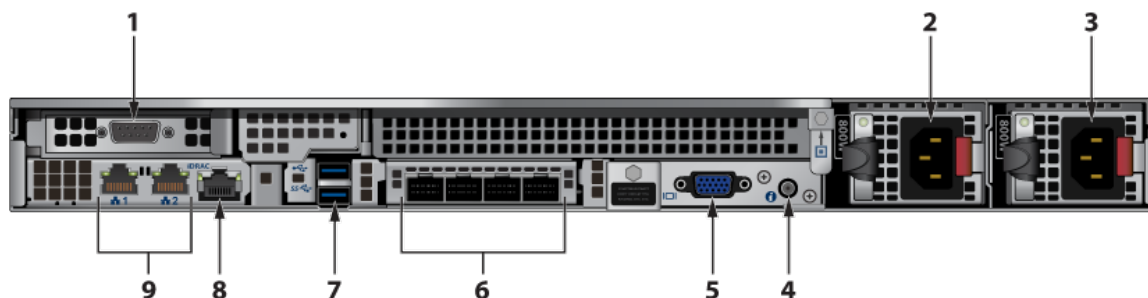

Table 18: Rear Panel Features and Indicators

Number	Indicator, Button, or Connector	Description
1	Serial connector	Allows you to connect a serial device to the system.
2	PSU1	Power supply 1
3	PSU2	Power supply 2
4	System identification button	<p>The identification buttons on the front and back panels can be used to locate a particular system within a rack. When one of these buttons is pressed, the system status indicator on the back flashes until one of the buttons is pressed again.</p> <p>Press to toggle the system ID on and off. If the system stops responding during POST, press and hold the system ID button for more than five seconds to enter BIOS progress mode.</p> <p>To reset the iDRAC (if not disabled in F2 iDRAC setup) press and hold the button for more than 15 seconds.</p>
5	Video connector	Allows you to connect a VGA display to the system.
6	Ethernet connectors	Unused
7	USB connector	Allows you to connect USB devices to the system. The port is USB 2.0-compliant.
8	iDRAC port	Dedicated management port for the iDRAC port card.
9	Ethernet connector	Admin interface and Data interface.

RoHS Declaration Statements

Figure 8-1: Chinese RoHS Statement

用户须知
Arista Networks
产品信息（适用于中华人民共和国）

按照中华人民共和国电子行业标准 SJ/T11364-2014《电子电气产品有害物质限制使用标识》的要求，本文档提供相关产品信息。

表 1 列出了 Arista Networks 产品（包括部件）中超出 GB/T 26572 限制的有毒有害物质或元素。

部件名称	有毒有害物质和元素 Toxic or hazardous Substances and Elements					
	铅 (Pb)	汞 (Hg)	镉 (Cd)	六价铬 (Cr6+)	多溴联苯 (PBB)	多溴联苯醚 (PBDE)
金属外壳	0	0	0	0	0	0
印刷电路板组件	X	0	0	0	0	0
紧固件	X	0	0	0	0	0
电源	X	0	0	0	0	0
安装硬件	0	0	0	0	0	0
电缆	0	0	0	0	0	0

0: 表示该部件的所有均质材料中的有毒有害物质含量低于 GB/T 26572 的限量值。
X: 表示该部件的所有均质材料中至少一种有毒有害物质含量高于 GB/T 26572 的限量值。

按照 GB/T 26572 的要求，Arista Networks 于中华人民共和国境内销售的所有产品均标有电子电气产品有害物质限制使用标识，以下标识适用于 Arista Networks 产品。

该标识说明，产品的某些均质材料中的有毒有害物质或元素含量超出 GB/T 26572 的限量值，已于表 1 列出这些物质。

某些产品由于尺寸或功能的限制，无法进行直接标记，这些产品也符合 SJ/T11364-2014 的要求，本文包含其标识信息。



上图所示的 20 指产品的环保使用年限 (EUP)，环保使用年限是指从生产日期开始，产品中的有毒有害物质或元素，在按照产品用户文档所述的正常使用条件下，不会发生外溢或突变、对环境造成严重污染或对人身、财产造成严重损害的年限。

注：除中华人民共和国法律强制性规定中的明确要求外，Arista Networks 不对环保使用年限做任何明示或暗示的陈述或保证，并明确表示不对环保使用年限承担任何明示或暗示的陈述或保证。

For the Taiwan BSMI RoHS Table, go to <https://www.arista.com/assets/data/pdf/AristaBSMIroHS.pdf>.